TEK

Service Reference

Part No. 070-6785-02
Product Group 47

**THE
11A34**

**FOUR-CHANNEL
AMPLIFIER**

WARNING

The following servicing instructions are for use by qualified personnel only. To avoid personal injury, do not perform any servicing unless you are qualified to do so. Refer to the Safety Summary prior to performing any service.

Please check for CHANGE INFORMATION at the rear of this manual.

Tektronix
COMMITTED TO EXCELLENCE

Instrument Serial Numbers

Each instrument manufactured by Tektronix has a serial number on a panel insert or tag, stamped on the chassis. The first letter in the serial number designates the country of manufacture. The last five digits of the serial number are assigned sequentially and are unique to each instrument. Those manufactured in the United States have six unique digits. The country of manufacture is identified as follows:

B010000	Tektronix, Inc., Beaverton, Oregon, USA
G100000	Tektronix Guernsey, Ltd., Channel Islands
E200000	Tektronix United Kingdom, Ltd., London
J300000	Sony/Tektronix, Japan
H700000	Tektronix Holland, NV, Heerenveen, The Netherlands

Instruments manufactured for Tektronix by external vendors outside the United States are assigned a two digit alpha code to identify the country of manufacture (e.g., JP for Japan, HK for Hong Kong, etc.).

Tektronix, Inc., P.O. Box 500, Beaverton, OR 97077

Copyright © Tektronix, Inc., 1987, 1989. All rights reserved. Tektronix products are covered by U.S. and foreign patents, issued and pending. The following are registered trademarks:

TEKTRONIX, TEK, TEKPROBE, SCOPEMOBILE and



Contents

Section 1 General Information	
Safety Summary	1-2
Terms in Manuals	1-2
Terms on Equipment	1-2
Symbols in Manuals	1-2
Symbols on Equipment	1-2
Power Source	1-2
Grounding the Product	1-2
Danger Arising from Loss of Ground	1-3
Do Not Operate in Explosive Atmospheres	1-3
Do Not Service Alone	1-3
Use Care When Servicing with Power On	1-3
Plug-in to Mainframe Compatibility	1-3
Installing and Removing the Plug-in	1-4
Instrument Options	1-5
Packaging for Shipment	1-5
Operating Environment	1-5
 Section 2 Checks and Adjustments	
Using These Procedures	2-6
Conventions in this Manual	2-6
Initialized Setting	2-7
Menu Selections and Measurement Techniques	2-7
Part 1 Initial Setup	2-8
Part 2 Enhanced Accuracy	2-9
Setup to Check Enhanced Accuracy	2-9
Procedure to Check Enhanced Accuracy	2-9
Part 3a High Frequency Response: Standard Procedure	2-11
Setup to Examine Mainframe High Frequency Response	2-11
Procedure to Examine Mainframe High Frequency Response	2-12
Setup to Examine/Adjust Amplifier Step Response (A1R1027, A1R1029, A1R1041, A1R1043)	2-13
Procedure to Examine/Adjust Amplifier Step Response (A1R1027, A1R1029, A1R1041, A1R1043)	2-13
Setup to Check Amplifier Bandwidth: Performance Verification Procedure	2-16
Procedure to Check Amplifier Bandwidth: Performance Verification Procedure	2-16
Setup to Check Amplifier Bandwidth: Functional Test Procedure	2-19
Procedure to Check Amplifier Bandwidth: Functional Test Procedure ..	2-19
Part 3b High Frequency Response: Alternate Procedure	2-20
Setup to Examine Mainframe High Frequency Response	2-20
Procedure to Examine Mainframe High Frequency Response	2-21
Setup to Examine/Adjust Amplifier Step Response (A1R1027, A1R1029, A1R1041, A1R1043)	2-22
Procedure to Examine/Adjust Amplifier Step Response (A1R1027, A1R1029, A1R1041, A1R1043)	2-22

Section 2 Checks and Adjustments (cont)	
Setup to Check Amplifier Bandwidth:	
Performance Verification Procedure	2-24
Procedure to Check Amplifier Bandwidth:	
Performance Verification Procedure	2-24
Setup to Check Amplifier Bandwidth: Functional Test Procedure	2-27
Procedure to Check Amplifier Bandwidth: Functional Test Procedure ..	2-27
Part 4 Overload	2-28
Setup to Check Overload	2-28
Procedure to Check Overload	2-28
Part 5 Input Resistance	2-30
Setup to Check Input Resistance	2-30
Procedure to Check Input Resistance	2-30
Part 6 Vertical Accuracy	2-31
Setup to Check Vertical Accuracy	2-31
Procedure to Check Vertical Accuracy	2-31
Check DC Balance—by performing Step 2.	2-32
Check Gain—by performing Steps 3 through 7.	2-32
Check Offset—by performing steps 8 through 11.	2-32
Part 7 Bandwidth Limit	2-33
Setup to Check Bandwidth Limit	2-33
Procedure to Check Bandwidth Limit	2-33
Part 8 AC Coupling	2-35
Setup to Check AC Coupling	2-35
Procedure to Check AC Coupling	2-35
Part 9 DC Balance	2-37
Setup to Check DC Balance	2-37
Procedure to Check DC Balance	2-37
Part 10a DV DC Accuracy: 11400-Series Mainframe Procedure	2-39
Setup to Characterize the 11400-Series Mainframe	2-39
Procedure to Characterize the 11400-Series Mainframe	2-39
Setup to Check the Amplifier DV DC Accuracy	2-40
Procedure to Check the Amplifier DV DC Accuracy	2-40
Specification	2-43
Setup to Characterize the 11300-Series Mainframe	2-43
Procedure to Characterize the 11300-Series Mainframe	2-43
Setup to Check the Amplifier DV DC Accuracy	2-44
Procedure to Check the Amplifier DV DC Accuracy	2-45
Part 11 DC Offset Accuracy	2-47
Setup to Characterize the 11400-Series Mainframe	2-47
Procedure to Characterize the 11400-Series Mainframe	2-47
Setup to Characterize the 11300-Series Mainframe	2-48
Procedure to Characterize the 11300-Series Mainframe	2-48
Setup to Check the Amplifier DC Offset Accuracy	2-49
Procedure to Check the Amplifier DC Offset Accuracy	2-51
Section 3 Maintenance	
Preventive Maintenance	3-1
Amplifier Shield Removal	3-1
Cleaning	3-1
Visual Inspection	3-2
Periodic Electrical Adjustment	3-2

Section 3 Maintenance (cont)	
Corrective Maintenance	3-3
Ordering Parts	3-3
Static-Sensitive Device Classification	3-3
Removing and Replacing FRUs	3-4
Removing/Replacing FRU ICs	3-6
Removing/Replacing the U350 Hypcon Assembly	3-8
Circuit Board and Attenuator FRU Removal	3-13
Programming The Unit Identification	3-17
Multi-Pin Connectors	3-18
Diagnostic Troubleshooting	3-19
Diagnostics Overview	3-19
New Configuration Calibration	3-22
Restoring Calibration Data	3-22
Plug-In Memory Backup Power	3-23
Field Replaceable Unit (FRU) Guide	3-23
Fuse Troubleshooting	3-27
Jumpers	3-28
Section 4 Theory of Operation	
Block Diagram Description	4-1
Signal Flow	4-1
Control Flow	4-3
Power	4-3
Section 5 Replaceable Parts	
Parts Ordering Information	5-1
Module Replacement	5-1
Using the Replaceable Parts List	5-2
Item Names	5-2
Indentation System	5-2
Abbreviations	5-2
Change Information	

List of Illustrations	Figure 1-1	Installing the 11A34 Amplifier in a Mainframe	1-4
	Figure 2-1	A1 Main Board Adjustment Locations	2-15
	Figure 3-1	Field Replaceable Units (FRU) Locator and A1 Main Board Securing Hardware	3-5
	Figure 3-2	Semiconductor Indexing Diagram	3-7
	Figure 3-3	Hypcon Assembly Removal and Replacement	3-10
	Figure 3-4	IC Insertion-Extraction Pliers	3-12
	Figure 3-5	Location of Screws and Parts for Removal of an Attenuator ..	3-15
	Figure 3-6	Location of a Nut Block Securing the Circuit Board to the Frame Section	3-16
	Figure 3-7	Indexing of Multi-pin Connectors	3-18
	Figure 3-8	Sample LED Fault Code Timing Diagram	3-20
	Figure 3-9	Jumper Locator	3-28
	Figure 4-1	11A34 Four-Channel Amplifier Block Diagram	4-2

List of Tables	Table 2-1	Measurement Limits, Specifications, Adjustments, and Functional Test	2-1
	Table 2-2	Test Equipment	2-4
	Table 2-3	11A34 Bandwidth	2-18
	Table 2-4	11A34 Bandwidth	2-26
	Table 2-5	11A34 Amplifier DC Balance	2-38
	Table 2-6	11A52 Amplifier DC Offset Accuracy	2-52
	Table 3-1	Relative Susceptibility to Damage from Static Discharge	3-4
	Table 3-2	Board FRU	3-23
	Table 3-3	Component/Module FRUs	3-24
	Table 3-4	Amplifier Kernel Error Index Codes	3-24
	Table 3-5	Self-Tests/Extended Diagnostics Error Index Codes	3-25
	Table 3-6	Self-Tests/Extended Diagnostics Error Index Codes	3-26

General Information

This manual is designed for use by qualified service personnel. It contains information necessary to check, maintain and troubleshoot the 11A34 Four-Channel Amplifier.

Troubleshooting is primarily based upon internal diagnostics. These diagnostics isolate problems to the field replaceable unit (FRU) level. Once the faulty FRU is identified, use the procedures in this manual to remove and replace the faulty FRU. Section 5, Replaceable Parts gives a complete list of the FRUs in this amplifier.

The 11A34 is a four-channel, wide-bandwidth, amplifier that plugs into any of the 11000-Series Oscilloscope mainframes that use amplifiers. Commands from the mainframe control all the functions of the amplifier. The front panel of the amplifier has a button and a LED indicator for each input channel. Other controls and status indicators are located on the mainframe.

The impedance of each channel is set independently to either 1 M Ω or 50 Ω . Bandwidth can be limited to 20 MHz or 100 MHz. Each channel provides a display and a trigger output to the mainframe. Each output is comprised of a combination of the input signals that the mainframe specifies. The amplifier also provides an auxiliary output from each channel to the mainframe.

Each channel has a TEKPROBE® input connector. The TEKPROBE® input connector is compatible with a Level 1 or Level 2 TEKPROBE®, a probe with a BNC connector, or a BNC connector. When a probe is connected to the input connector, the amplifier will detect the probe-encoding information, and use this information to automatically achieve the appropriate settings.

Safety Summary

This general safety information is directed to operators and service personnel. Specific warnings and cautions will be found throughout the manual where they apply, but may not appear in this summary.

Terms in Manuals

CAUTION statements in manuals identify conditions or practices that could result in damage to the equipment or other property.

WARNING statements in manuals identify conditions or practices that could result in personal injury or loss of life.

Terms on Equipment

CAUTION on equipment means a personal injury hazard not immediately accessible as one reads the marking, or a hazard to property; including the equipment itself.

DANGER on equipment means a personal injury hazard immediately accessible as one reads the marking.

Symbols in Manuals



Static Sensitive Devices

Symbols on Equipment



DANGER
High Voltage



Protective
ground (earth)
terminal



ATTENTION
Refer to
manual

Power Source

This amplifier is intended to operate in a mainframe connected to a power source that will not apply more than 250 V rms between the supply conductors or between either supply conductor and ground. A protective ground connection, by way of the grounding conductor in the mainframe power cord, is essential for safe system operation.

Grounding the Product

This amplifier is grounded through the grounding conductor of the mainframe power cord. To avoid electric shock, plug the mainframe power cord into a properly wired receptacle before connecting the mainframe to the input or output terminals of the amplifier. A protective-ground connection, by way of the grounding conductor in the mainframe power cord, is essential for safe operation.

Danger Arising from Loss of Ground

Upon loss of the protective-ground connection, all accessible conductive parts (including knobs and controls that may appear to be insulating), can render an electric shock.

Do Not Operate in Explosive Atmospheres

To avoid explosion, do not operate this product in an atmosphere of explosive gasses.

Do Not Service Alone

Do not perform internal service or adjustment of this product unless another person capable of rendering first aid and resuscitation is present.

Use Care When Servicing with Power On

Dangerous voltages exist at several points in this product. To avoid personal injury, do not touch exposed connections and components while the power is on.

Disconnect the power before removing protective panels, or replacing components.

**Plug-in to Mainframe
Compatibility**

The system bandwidth depends on the mainframe. Details about bandwidth are included in Part 4, Specification, of the *11A34 User's Reference Supplement*, and in the *Tektronix Corporate Catalog*. Refer to the *Tektronix Corporate Catalog* for complete compatibility information.

Installing and Removing the Plug-in

Install the amplifier in any 11000-Series Oscilloscope mainframe as follows:

1. Set the mainframe ON/STANDBY switch to STANDBY to prevent damage to the mainframe.

If the green indicator light remains ON when the STANDBY position is selected, then the switch has been left internally disabled after the servicing of the power supply. To enable the ON/STANDBY switch, refer to the Maintenance section of the mainframe Service Manual.

2. Align the grooves in the top and bottom of the amplifier with the guides in the mainframe plug-in compartment.
3. Insert the amplifier into the mainframe until its front panel is flush with the front panel of the mainframe.

Remove the amplifier from an 11000-Series Oscilloscope mainframe as follows:

1. Set the mainframe ON/STANDBY switch to STANDBY to prevent damage to the mainframe.
2. Pull the release latch (see Fig. 1-1) to disengage the amplifier from the mainframe.
3. Pull the amplifier straight out of the plug-in compartment.

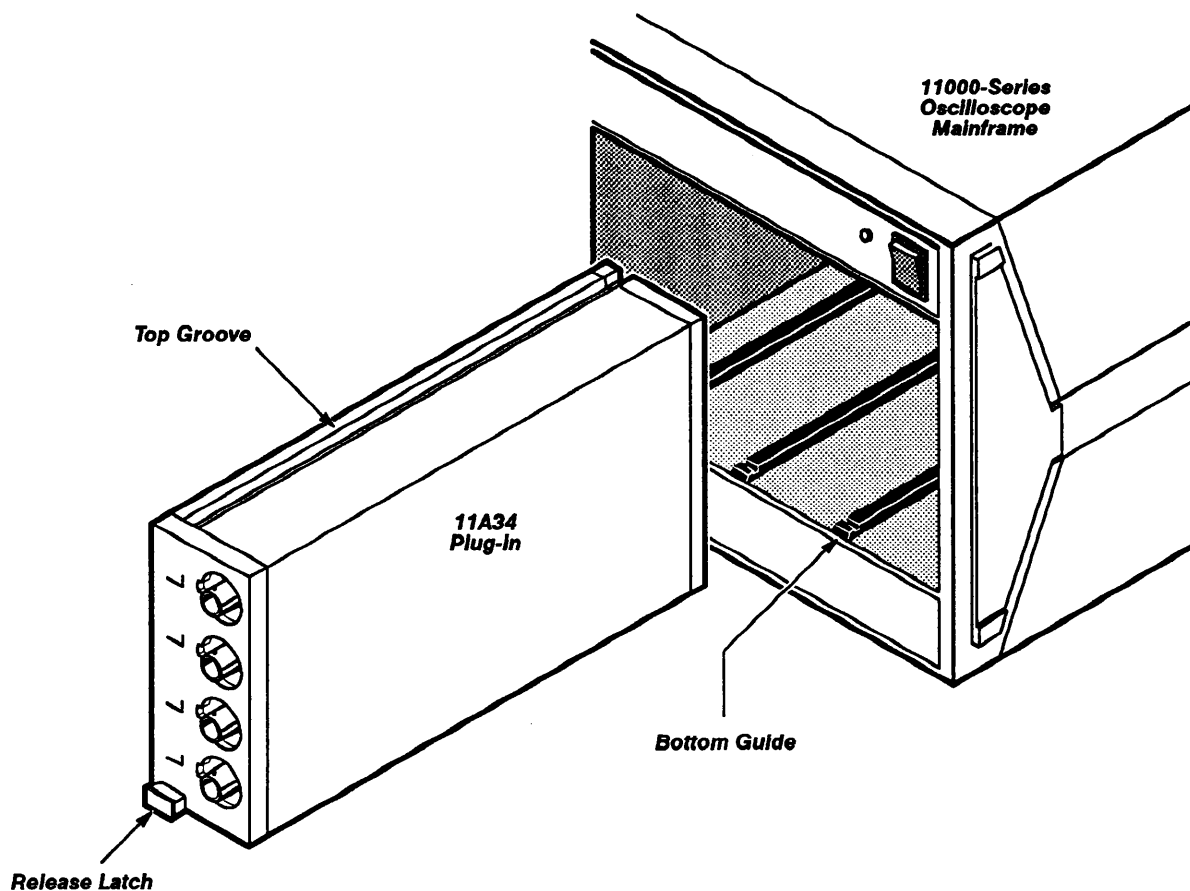

Figure 1-1 — Installing the 11A34 Amplifier in a Mainframe

Instrument Options

The customer can order Option 23, which includes four P6134 probes.

Packaging for Shipment

If possible, save and reuse the original carton and packaging to package the instrument when shipping it by commercial transportation. Package and ship amplifiers and mainframes separately.

Attach a tag to the amplifier if it is shipped to a Tektronix service center for service or repair. Include the following information on the tag:

- Name and address of the amplifier owner
- Name of a person at your firm who can be contacted about the amplifier
- Complete amplifier type and serial number
- A description of the service required

Package the amplifier as follows, if the original package is not available or is not reusable:

1. Obtain a corrugated cardboard carton with inside dimensions at least six inches (15 cm) greater than the amplifier dimensions. Use a carton with a bursting test strength of at least 200 pounds per square-inch.
2. Fully wrap the amplifier with anti-static sheeting, or its equivalent, to protect the finish.
3. Tightly pack dunnage or urethane foam between the carton and the amplifier to cushion the amplifier on all sides. Allow three inches of packing on each side.
4. Seal the carton with shipping tape or with industrial staples.
5. Mark the address of the Tektronix service center and your return address on the carton in one or more prominent places.

Operating Environment

The following environmental requirements are provided so that you can ensure proper functioning and extend the operation of the amplifier:

- Operate the amplifier in a mainframe where the ambient air temperature is between 0° and +50°C.
- Store the amplifier in ambient temperatures from -40° to +75°C.
- After storing the amplifier at temperatures outside the operating limits, allow the amplifier to reach the safe operating temperature before installing it in the mainframe, and applying power to the mainframe.

Enhanced system accuracy is available after a 20-minute warmup period. If the mainframe is in the Enhanced Accuracy state and the internal temperature of the mainframe changes $\pm 5^{\circ}\text{C}$, the mainframe reverts to normal accuracy.

Checks and Adjustments

This section contains procedures to examine measurement limits, check electrical specifications, and to manually set all internal adjustments. This procedure provides a logical sequence of check and adjustment steps, and is intended to return the amplifier to specified operation following repair, or as a part of a routine maintenance program. To functionally test the oscilloscope, perform the parts which have a "yes" indication in the Functional Test column of Table 2-1, Measurement Limits, Specifications, Adjustments and Functional Test.

Refer to the *11A34 User's Reference Supplement* for more information about advertised specifications and amplifier operation. At the beginning of each part the specifications or measurement limits are given. Then, the setup for each procedure in that part provides information concerning test equipment setup or interconnection. Refer to Table 2-2, Test Equipment for more information concerning test equipment used in these setups.

Table 2-1 – Measurement Limits, Specifications, Adjustments, and Functional Test

Part and Description	Measurement Limits (Examine)	Specifications (Check)	Adjustments (Adjust)	Functional Test
Part 1 Initial Setup	none	none	none	yes
Part 2 Enhanced Accuracy	none	none	successful execution	yes
Part 3a High Frequency Response: Standard Procedure				
Mainframe High Frequency Response	none	none	none	no
Amplifier Step Response	difference between two waveform aberrations $\leq 4.5\%$ peak and 7% p-p	none	HF1, HF2, HF3, and HF4 so that the CH1, CH2, CH3, and CH4 aberrations respectively, are within 4.5% peak and 7% p-p	no
Amplifier Bandwidth: Performance Verification Procedure	none	refer to Table 2-3 for the bandwidth specifications	none	no
Amplifier Bandwidth: Functional Test Procedure	none	peak-peak measurement ≥ 848 mV	none	yes

Table 2-1 – Measurement Limits, Specifications, Adjustments, and Functional Test (cont)

Part and Description	Measurement Limits (Examine)	Specifications (Check)	Adjustments (Adjust)	Functional Test
Part 3b High Frequency Response: Alternate Procedure				
Mainframe High Frequency Response	none	none	none	no
Amplifier Step Response	difference between two waveform aberrations $\leq 4.5\%$ peak and 7% p-p	none	HF1, HF2, HF3, and HF4 so that the CH1, CH2, CH3, and CH4 aberrations respectively, are within 4.5% peak and 7% p-p	no
Amplifier Bandwidth: Performance Verification Procedure	none	refer to Table 2-4 for the bandwidth specifications	none	no
Amplifier Bandwidth: Functional Test Procedure	none	peak-peak measurement ≥ 848 mV	none	yes
Part 4 Overload	none	input impedance goes to 1 M Ω	none	yes
Part 5 Input Resistance	none	1 M $\Omega \pm 5$ k Ω 50 $\Omega \pm 0.5$ Ω	none	yes
Part 6 Vertical Accuracy				yes
DC Balance	none	from 5 mV to 10 V, trace within ± 0.2 divs of center. from 1 mV to 2 mV, trace within ± 1 div of center	none	
Gain	none	peak-peak measurement is 5 V ± 90 mV for the 11300-Series and 5 V ± 57 mV for the 11400-Series	none	
DC Offset	none	top of waveform vertically centered within ± 0.5 divisions	none	

Table 2-1 – Measurement Limits, Specifications, Adjustments, and Functional Test (cont)

Part and Description	Measurement Limits (Examine)	Specifications (Check)	Adjustments (Adjust)	Functional Test
Part 7 Bandwidth Limit	none	at 100 MHz limit: 2.45 ns < rise time < 4.55 ns at 20 MHz limit: 12.3 ns < rise time < 22.7 ns	none	yes
Part 8 AC Coupling	none	bottom of square wave near center graticule line and waveform centered on screen	none	yes
Part 9 DC Balance	none	refer to Table 2-5	none	no
Part 10a ΔV DC Accuracy: 11400-Series Mainframe Procedure	none	within $\pm 0.63\%$	none	no
Part 10b ΔV DC Accuracy: 11300-Series Mainframe Procedure	none	within $\pm 1.2\%$	none	no
Part 11 DC Offset Accuracy	none	refer to Table 2-6	none	no

Table 2-2, Test Equipment, lists recommended test equipment for use in this manual. The Functional Test column of Table 2-2 indicates, with a check mark (✓), the test equipment that is recommended if you are only performing a functional test. Procedure steps are based on the test equipment examples given, but other equipment with similar specifications may be substituted. Test results, setup information, and related connectors and adapters may be altered if you use different equipment.

Table 2-2 – Test Equipment

Description	Minimum Specification	Examples of Recommended Test Equipment	Functional Test
11000-Series Oscilloscope mainframe that accommodates amplifiers	Tektronix mainframe that accommodates amplifiers	TEKTRONIX 11301 Programmable Oscilloscope 11302 Programmable Oscilloscope 11301A Counter Timer Oscilloscope 11302A Counter Timer Oscilloscope 11401 Digitizing Oscilloscope 11402 Digitizing Oscilloscope 11403 Digitizing Oscilloscope	✓
Power Module	Tektronix four-compartment power module	TEKTRONIX TM 504 Power Module	
Leveled Sine Wave Generators	250 MHz to 1000 MHz, Leveled variable amplitude, 50 kHz or 6 MHz reference	TEKTRONIX SG 504 Leveled Sine Wave Generator with a TM 500-Series Power Module	✓
	260 kHz to 250 MHz, Leveled variable amplitude, 50 kHz or 6 MHz reference	TEKTRONIX SG 503 Leveled Sine Wave Generator with a TM 500-Series Power Module	
Power Supply	Continuously variable from 0–40 V; current limit, adjustable from 0–400 mA; 20 V at 400 mA with overcurrent protection	TEKTRONIX PS 503A Dual Power Supply with a TM 500-Series Power Module	✓
DC Voltage Calibrator (optional)	Output, 0–4 V	Data Precision 8200	
Pulser	Amplitude: 250 mV Rise time: ≤ 125 ps Aberrations: $< 1\%$	TEKTRONIX 067-0681-01 Tunnel diode Calibration Fixture	
Digital Multimeter (w/test leads)	Accuracy $\leq 0.01\%$	Fluke 8842A Digital Multimeter	✓
Signal Standardizer	Tektronix Calibration Fixture with interface connector modified for 11000-Series use	TEKTRONIX 067-0587-02 Signal Standardizer	

Table 2-2 – Test Equipment (cont)

Description	Minimum Specification	Examples of Recommended Test Equipment	Functional Test
Calibration Generator	Period, 0.1 ms Amplitude, –60 V Square wave output, 0.25% accuracy, 1-2-5 amp selection from 200 μ V p-p to 100 p-p, ~ 1 ms period, fast rise < 1 ns	TEKTRONIX PG 506 Calibration Generator with a TM 500-Series Power Module	✓
Coaxial Cable, 36-inch (2 required)	50 Ω , 36-inch male BNC connectors	Tektronix Part 012-0482-00	
Coaxial Cable, 42-inch (2 required)	50 Ω , 42-inch male BNC connectors	Tektronix Part 012-0057-01	✓
Adapter, BNC to Alligator Clips	BNC Female to Clip leads	Tektronix Part 013-0076-00	
Term Conn Link	Shorting strap	Tektronix Part 131-0993-00	
Attenuator, 10X	Impedance: 50 Ω , one male and one female BNC connector	Tektronix Part 011-0059-02	
Adapter, BNC-to-Banana (2 required)	BNC Female-to-Dual Banana Connector	Tektronix Part 103-0090-00	✓
Adapter, T	BNC, T: Two female and one male BNC connector	Tektronix Part 103-0030-00	✓
50 Ω Termination	Impedance: 50 Ω ; Accuracy, within 2%; connectors, BNC	Tektronix Part 011-0049-01	
Resistor	430 Ω , 10% tolerance; power rating, 1 W	Tektronix Part 303-0431-00	
Alignment Tool (insulated slot)	Insulated slot	Tektronix Part 003-0675-01	
Magnetic Screwdriver	Holder for Torx tips	Tektronix Part 003-0293-00	
Torx Screwdriver Tips	#6 tip #7 tip #8 tip #10 tip #10 tip narrow shank #15 tip	Tektronix Part 003-1415-00 Tektronix Part 003-1293-00 Tektronix Part 003-0964-00 Tektronix Part 003-0814-00 Tektronix Part 003-0815-00 Tektronix Part 003-0966-00	
Integrated Circuit Extracting Tools	IC insertion-extraction pliers, 28-pin type	General Tool P/N U505BG or equivalent	

Table 2-2 – Test Equipment (cont)

Description	Minimum Specification	Examples of Recommended Test Equipment	Functional Test
Needle-nose pliers			
Tweezers			
Static Control Mat		Tektronix Part 006-3414-00	
Wrist Strap		Tektronix Part 006-3415-00	

Using These Procedures

The first-time user should familiarize themselves with the proceeding information prior to performing the procedures in the parts that follow.

Conventions in this Manual

In these procedures, the following conventions are used:

- CAPITAL letters within the body of text identify front panel controls, indicators, and connectors (for example, MEASURE) on the mainframe and amplifier.
- **Bold** letters identify menu labels, display messages, and commands typed in from a terminal or controller.
- Initial Capital letters identify connectors, controls, and indicators (for example, Position) on associated test equipment. Initial Capital letters also identify adjustments inside the amplifier (for example Vert Pos).
- In some steps, the first word is italicized to identify a step that contains a performance verification and/or an adjustment instruction. For example, if *Check* is the first word in the title of a step, an electrical specification is checked. If *Adjust* appears in the title, the step involves an electrical adjustment. If *Examine* is the first word in the title, the step involves measurement limits that are used as calibration guides; these limits are not to be interpreted as electrical specifications.

A heading system is used to readily identify the steps that contain performance verification and/or adjustment instructions. For example, if *Check* is the first word in the title of a step, an electrical specification is checked. If *Adjust* appears in the title, the step involves an electrical adjustment. If *Examine* is the first word in the title, the step concerns measurement limits that indicate whether the instrument is operating properly; these limits are not to be interpreted as electrical specifications.

Initialized Setting

At the beginning of most steps, you are instructed to **Initialize** the instrument as part of the setup. The **Initialize** feature, available through the UTILITY menu, presets all mainframe controls and functions to known values. Initializing the instrument at the beginning of a step eliminates the possibility of settings from previous steps causing erroneous or confusing results. For more information on initialization, refer to the mainframe *User Reference* manual.

Menu Selections and Measurement Techniques

Details on measurement techniques and instructions for making menu selections are generally not included in this procedure. Comprehensive descriptions of menus and instrument features are located in the mainframe *User Reference* manual.

Part 1 Initial Setup



Perform the Checks and Adjustment procedure within the ambient temperature range of +18° and +28°C, to ensure proper mainframe and amplifier operation.

To avoid damage to any of the equipment, set the mainframe ON/STANDBY switch to STANDBY before installing or removing amplifiers.

Turning the mainframe power off during probe calibration, self-calibration, Extended Diagnostics, or other intense system activity may result in some internal data being corrupted. If corruption occurs, refer to Restoring Calibration Data in Section 3.

- Step 1: Power on the following test equipment, so that it is warmed up with the mainframe and amplifier to be tested.

Power supply
Calibration generator
Leveled sine wave generators
Digital multimeter

- Step 2: With the ON/STANDBY switch set to STANDBY, connect the mainframe to a suitable power source.
- Step 3: Install a signal standardizer in the Center plug-in compartment and the 11A34 Amplifier in the Left plug-in compartment. If you are performing a functional test, it is not necessary to install the signal standardizer.
- Step 4: Set the front panel ON/STANDBY switch to ON.
- Step 5: Allow the equipment to warm up for 20 minutes before continuing.

Part 2 Enhanced Accuracy

When displayed, the Enhanced Accuracy symbol (EA) indicates that the instrument is at its highest Accuracy state. The mainframe saves the time of calibration and ambient temperature for use in maintaining the Enhanced Accuracy state.

For more information about the Enhanced Accuracy state, see Enhanced Measurement Accuracy Indicator in the mainframe *User Reference* manual.

While Enhanced Accuracy is in effect, to verify the DC measurement accuracy of the amplifier and mainframe system, apply and monitor test voltages, and compare these test voltages with the measurements made on the screen.

Specification

When invoked, the self-calibration activity executes successfully.

Setup to Check Enhanced Accuracy

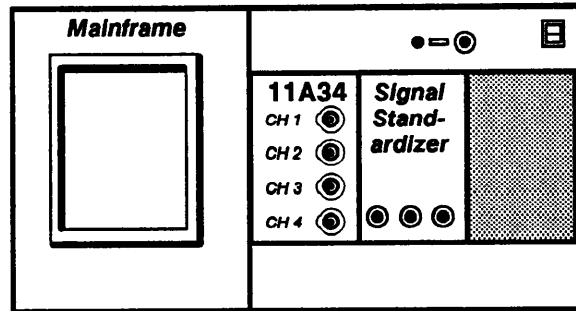

Setup to Check Enhanced Accuracy

Procedure to Check Enhanced Accuracy

- Step 1: Initialize the mainframe's settings.

Left plug-in	no setting changes
Mainframe	no setting changes
Signal standardizer	not used in this part

- Step 2: Twenty minutes after power-on, the mainframe must recalibrate itself to achieve the Enhanced Accuracy state. Press the ENHANCED ACCURACY button. A prompt then appears on the display. Press the ENHANCED ACCURACY button again. Enhanced Accuracy is achieved after a couple of minutes.



Turning the mainframe's power off during Enhanced Accuracy testing may result in losing some of the non-volatile RAM data. This could cause diagnostic errors at the next power-up, and cause the mainframe to operate unpredictably. If this event occurs, refer to Restoring Calibration Data in your mainframe's Service Reference manual.

- Step 3: *Check* that the message, **Enhanced Accuracy in Progress** (indicating that the mainframe is attempting to achieve Enhanced Accuracy) appears.
- Step 4: *Check* that the message, **Enhanced Accuracy completed and passed** or **Self calibration completed successfully** (indicating that the Enhanced Accuracy state has been achieved) appears. (The **EA** indicator appears on the display when Enhanced Accuracy is completed.)

Part 3a
High Frequency
Response:
Standard Procedure

The amplifier high frequency peaking is adjusted so that the bandwidth is adequate and the aberrations are not excessive. The Standard Procedure uses an 11400-Series mainframe to ensure that the amplifier performs properly in any mainframe. If an 11400-Series mainframe is not available, then use the Alternate Procedure at the end of this part.

First, the signal standardizer provides a reference waveform to characterize the mainframe high frequency response. Mainframe aberrations are displayed at 2% per division. Amplitude is measured at specification frequencies.

Then, the step response waveform is compared with the characterizations of the waveform in the Procedure to Examine Mainframe High Frequency Response to determine the amplifier's contribution to the aberrations.

Finally, the displayed amplitude is checked at the specification frequencies to determine the amplifier's contribution to the bandwidth.

Measurement Limits

The difference between the two waveform aberrations should not exceed 4.5% peak (2.25 divisions) and 7% (3.5 divisions) peak-to-peak. (One major graticule division = 2%.)

Specification (Performance Verification)

Refer to Table 2-3 for the bandwidth specifications.

Specification (Functional Test)

A peak-peak measurement ≥ 848 mV.

Setup to Examine Mainframe High Frequency Response

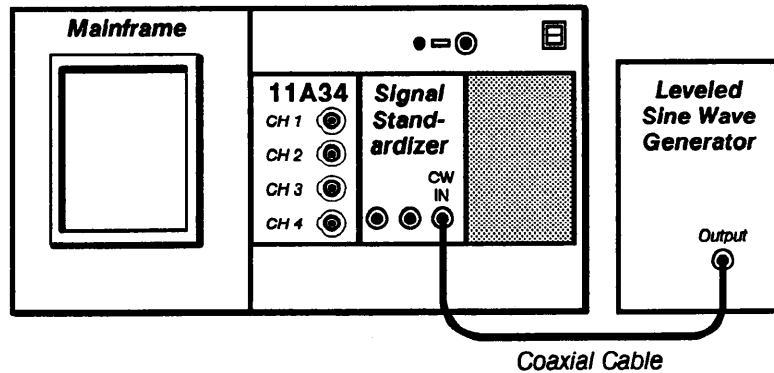

Setup to Examine Mainframe High Frequency Response

Procedure to Examine Mainframe High Frequency Response

- Step 1: First **Initialize** the mainframe's settings, then perform the following settings in the order listed:

Mainframe

UTILITY major menu **Instrument Options or Modes
Waveform Scaling (Forced)**

Def Wfm **C (center)**

TRIGGER major menu **Source Desc**

Main Trigger Source Description pop-up menu **C (center)**

Left plug-in not used in this procedure

Signal standardizer

Test **Vert or Horiz + Step Resp**

Rep Rate **100 kHz**

Position **12 o'clock**

Amplitude **9 o'clock**

Mainframe

Main Size **2 ns/div**

Trig Level **40%**

Main Pos **position positive pulse transition
one division from left edge of graticule**

Acquire Desc pop-up menu

Average N **On**

Set Avg N **8**

Signal standardizer

Amplitude **5-division vertical step**

Mainframe

Vert Pos: Wfm **position top of step on center
horizontal graticule line**

Vert Mag: Wfm **100 mV**

Leveled sine wave generator

Frequency **Ref**

- Step 2: Record the displayed waveform on graph paper or make a hardcopy of the display. This waveform is used in the Procedure to Examine/Adjust Amplifier Step Response for comparison against the amplifier step response.
- Step 3: Set **Average N** to **Off**. Set **Main Size** to 10 μ s/div.
- Step 4: Set the signal standardizer Test switch to Vert or Horiz Freq Resp.
- Step 5: Set the leveled sine wave generator output amplitude so that the signal standardizer CW Leveled light is on. Ensure that the light remains on throughout the following steps. The reference frequency must be between 50 kHz and 6 MHz.
- Step 6: Set the signal standardizer Position and Amplitude for a 6-division display amplitude, centered on the screen.

- Step 7: Set the leveled sine wave generator frequency to each Test Frequency in column (1) of Table 2-3, and record the Displayed Amplitude in column (2) on a copy of Table 2-3. This data is used in the Procedure to Check Amplifier Bandwidth for calculating the amplifier bandwidth.

This procedure may require more than one leveled sine wave generator to test all the Test Frequencies listed. When changing to another leveled sine wave generator, repeat Steps 5 and 6.

- Step 8: Set the mainframe ON/STANDBY switch to STANDBY.
- Step 9: Remove the signal standardizer from the Center plug-in compartment. Remove the amplifier from the Left plug-in compartment and install it in the Center plug-in compartment.

**Setup to Examine/Adjust Amplifier Step Response
(A1R1027, A1R1029, A1R1041, A1R1043)**

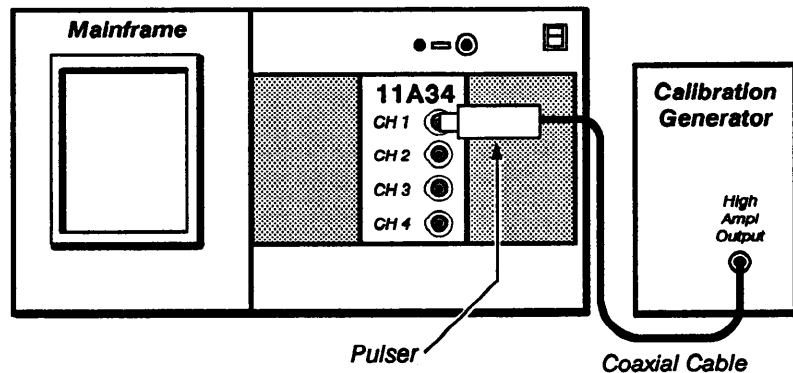

Setup to Examine/Adjust Amplifier Step Response

**Procedure to Examine/Adjust Amplifier Step Response
(A1R1027, A1R1029, A1R1041, A1R1043)**

- Step 1: Perform the following settings in the order listed:
 - Remove the left side cover from the amplifier.
 - Insert the amplifier into the mainframe Center plug-in compartment.
 - Connect the pulser to the CH 1 input connector.
 - Connect a 50 Ω coaxial cable from the calibration generator High Ampl Output connector to the pulser.

Calibration generator

Function switch High Ampl
 Period 0.1 ms
 Pulse Amplitude Max

Pulser

TD Triggered Level fully clockwise

Mainframe

ON/STANDBY switch ON
 Wait for calibration cycle to complete
 UTILITY major menu **Initialize**
 UTILITY major menu **Instrument Options or Modes
 Waveform Scaling (Forced)**

Center plug-in

CH 1 Display on/off on

Mainframe

Vert Size 50 mV/div
Impedance 50 Ω
Main Size 1 μ s/div
Main Pos position positive-going edge to first
 graticule line from left edge of graticule

Pulser

TD Triggered Level rotate control counterclockwise
 until the step disappears, then rotate
 clockwise just enough to obtain a step

Mainframe

Main Size 2 ns/div
Main Pos position positive-going edge between the first and
 second graticule lines from the left edge of the graticule
Vert Offset position top of step 2.5 divisions above
 the center horizontal graticule line

Acquire Desc pop-up menu

Average N On
Set Avg N 8
Numeric Entry & Knob Res pop-up menu **Fine**
Vert Size 5-division step amplitude display
Vert Offset position right side of trace to the
 center horizontal graticule line
Vert Size set readout for 10% of present readout (\sim 4 mV/div)
Vert Offset position right side of trace to the
 center horizontal graticule line

- Step 2: *Examine* the displayed waveform with the waveform recorded in the previous Procedure to Examine Mainframe Step Response and examine the amplifier's contribution for aberrations within 4.5% peak (2.25 divisions) and 7% peak-to-peak (3.5 divisions). (You can use Δ Vert cursors or **Horizontal Bars** to measure this amplitude.)



DO NOT attempt to optimize the aberrations if they are within the stated limits. Proceed to Step 4.

- Step 3: *Adjust* HF1, R1027 on the A1 Main board, so that the CH 1 aberrations are within 4.5% peak (2.25 divisions) and 7% peak-to-peak (3.5 divisions). Refer to Figure 2-1 for adjustment locations.
- Step 4: Remove the displayed waveform.

- Step 5: Move the pulser to the CH 2 input connector. Then, repeat Step 1 beginning at the Center plug-in settings and proceeding through Steps 2, 3, and 4 in this procedure (the adjustment is performed using the HF2 adjustment, R1029).
- Step 6: Move the pulser to the CH 3 input connector. Then, repeat Step 1 beginning at the Center plug-in settings and proceeding through Steps 2, 3, and 4 in this procedure (the adjustment is performed using the HF3 adjustment, R1041).
- Step 7: Move the pulser to the CH 4 input connector. Then, repeat Step 1 beginning at the Center plug-in settings and proceeding through Steps 2, 3, and 4 in this procedure (the adjustment is performed using the HF4 adjustment, R1043).

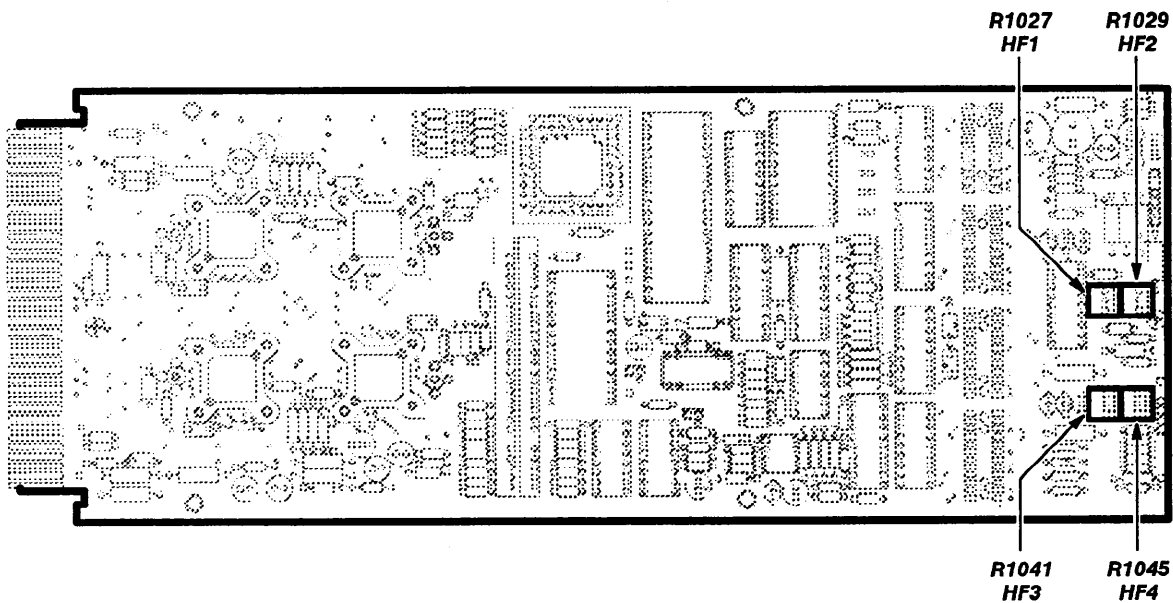
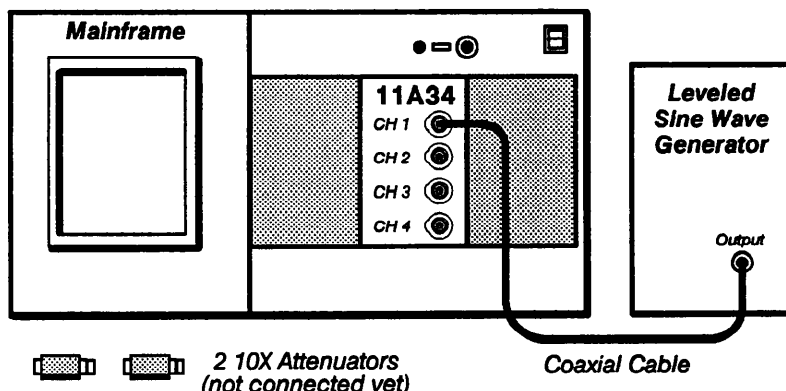

Figure 2-1 – A1 Main Board Adjustment Locations

Setup to Check Amplifier Bandwidth: Performance Verification Procedure



Setup to Check Amplifier Bandwidth: Performance Verification Procedure

Procedure to Check Amplifier Bandwidth: Performance Verification Procedure

Step 1: First **Initialize** the mainframe's settings, then perform the following settings in the order listed:

- Center plug-in
- CH1 Display on/off on
- Mainframe
- Main Size** 10 μ s/div
- Impedance** 50 Ω
- Leveled sine wave generator
- Amplitude 4 V p-p
- Frequency Ref

If the leveled sine wave generator has a remote leveling head, then you must connect it to the amplifier input connector without additional coaxial cables.

The reference frequency must be between 50 kHz and 6 MHz.

Perform this procedure for each Vertical Size listed in column (3) of Table 2-3; then repeat for CH 2.

This procedure may require the use of more than one leveled sine wave generator to test all the frequencies listed in Table 2-3.

If the leveled sine wave generator is not equipped with internal attenuators, then use the 10X attenuators at the amplifier input when setting amplitude.

To measure the amplitude, either count the divisions, or use the ΔV cursors.

Step 2: Set the leveled sine wave generator amplitude as shown in the Reference Amplitude column (4).

Step 3: Set the leveled sine wave generator frequency as shown in the Frequency column (1).

- Step 4: Record the Displayed Amplitude in column (5).
- Step 5: *Check* that the amplifier amplitude, computed by dividing column (5) by column (2), is at least the value shown in column (6).
- Step 6: Set the leveled sine wave generator to the reference frequency.

If there are any failures, then the step response must be readjusted for the appropriate deflection factors, so that the Measurement Limits for step response aberrations and the Specifications for bandwidth are both met.

Table 2-3 — 11A34 Amplifier Bandwidth

(1) Test Frequency MHz	(2) Mainframe with Standardizer	(3) Vertical Size	(4) Reference Amplitude: div	(5) Mainframe with Amplifier				(6) Amplifier only					
				Displayed Amplitude: div					Calculated Amplitude: col (5) + col (2)				
				CH 1	CH 2	CH 3	CH 4						
300	—	1 V/div	4	—	—	—	—	CH 1	CH 2	CH 3	CH 4	—	
300	—	500 mV/div	6	—	—	—	—	—	—	—	—	—	—
300	—	50 mV/div	6	—	—	—	—	—	—	—	—	—	—
300	—	20 mV/div	6	—	—	—	—	—	—	—	—	—	—
300	—	10 mV/div	6	—	—	—	—	—	—	—	—	—	—
250	—	5 mV/div	6	—	—	—	—	—	—	—	—	—	—
200	—	2 mV/div	6	—	—	—	—	—	—	—	—	—	—
150	—	1 mV/div	6	—	—	—	—	—	—	—	—	—	—

Setup to Check Amplifier Bandwidth: Functional Test Procedure

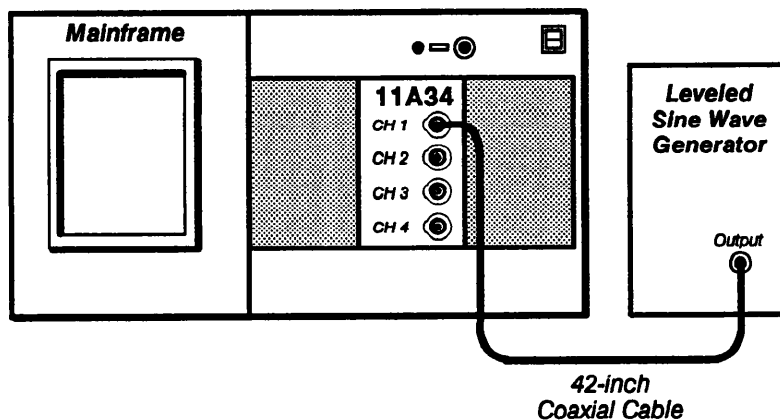

Setup to Check Amplifier Bandwidth: Functional Test Procedure

Procedure to Check Amplifier Bandwidth: Functional Test Procedure

- Step 1: First **Initialize** the mainframe's settings, then perform the following settings in the order listed:

Amplifier

CH 1 Display on/off on
 Leveled sine wave generator
 Frequency Ref (6 MHz)

Mainframe

Impedance 50 Ω
Vert Size 200 mV/div
Main Size 100 ns/div

- Step 2: Select the **Peak-Peak** measurement to measure the peak-to-peak amplitude of the waveform.
- Step 3: Set the leveled sine wave generator for 1.2 V peak-to-peak.
- Step 4: Set the leveled sine wave generator Frequency control to the maximum bandwidth frequency specified for the mainframe-amplifier combination. This limit is displayed as **BW Limit** (WAVEFORM button).
- Step 5: Set the **Main Size** to display several cycles of the waveform.
- Step 6: *Check* that the measurement is at least 848 mV (70.7% of Step 3).
- Step 7: Set the CH 1 display on/off button to off.
- Step 8: Move the coaxial cable to the CH 2 input and set its display on/off to on.
- Step 9: Perform the Steps 1 to 8 for the remaining channels.

Part 3b
High Frequency
Response:
Alternate Procedure

The amplifier high frequency peaking is adjusted so that the bandwidth is adequate and the aberrations are not excessive. This Alternative Procedure is used when the available mainframe is an 11300-Series. Performance is assured only for the particular amplifier and mainframe combination examined and adjusted during this procedure.

First, the mainframe performance is characterized at the specification frequencies using the signal standardizer.

Then, the amplifier and mainframe aberrations are displayed at 20% per division.

Finally, the displayed amplitude is checked at the specification frequencies to determine the amplifier's contribution to the bandwidth.

Measurement Limits

The waveform aberrations should not exceed 4.5% peak (0.225 division) and 7% (0.35 division) peak-to-peak. One major graticule division = 20%.

Specification (Performance Verification)

Refer to Table 2-4 for the bandwidth specifications.

Specification (Functional Test)

A peak-peak measurement ≥ 848 mV.

Setup to Examine Mainframe High Frequency Response

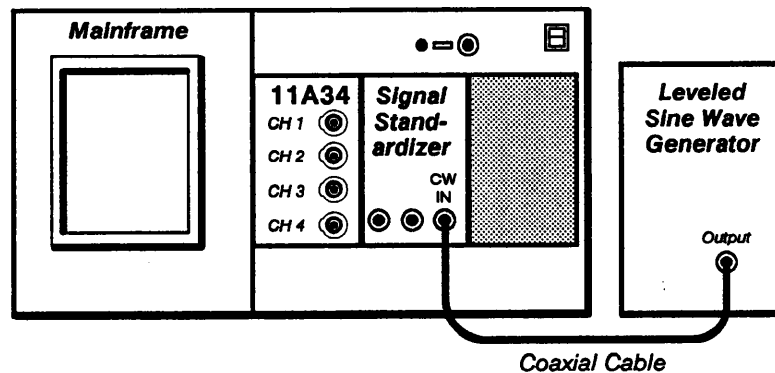

Setup to Examine Mainframe High Frequency Response

Procedure to Examine Mainframe High Frequency Response

- Step 1: First **Initialize** the mainframe's settings, then perform the following settings in the order listed:

Mainframe

Waveform C (center)
Trigger Source C (center)
HORIZONTAL SIZE 10 μ s/div
Left plug-in not used in this procedure
Signal standardizer
Test Vert or Horiz Freq Resp
Leveled sine wave generator
Frequency Ref

The reference frequency must be between 50 kHz and 6 MHz.

- Step 2: Set the leveled sine wave generator output amplitude so that the signal standardizer CW Leveled light is on. Ensure that the light remains on throughout the following steps.
- Step 3: Set the signal standardizer Position and Amplitude for a 6-division display amplitude, centered on the screen.
- Step 4: Set the leveled sine wave generator frequency to each Test Frequency in column (1) of Table 2-4, and record the displayed amplitude in the Displayed Amplitude column (2) on a copy of Table 2-4. This data is used in the Procedure to Check Amplifier Bandwidth for calculating the amplifier bandwidth.

This procedure may require more than one leveled sine wave generator to test all the Test Frequencies listed. When changing to another leveled sine wave generator, repeat Steps 2 and 3.

- Step 5: Set the mainframe ON/STANDBY switch to STANDBY.
- Step 6: Remove the signal standardizer from the Center plug-in compartment. Remove the amplifier from the Left plug-in compartment, and install it in the Center plug-in compartment.

**Setup to Examine/Adjust Amplifier Step Response
(A1R1027, A1R1029, A1R1041, A1R1043)**

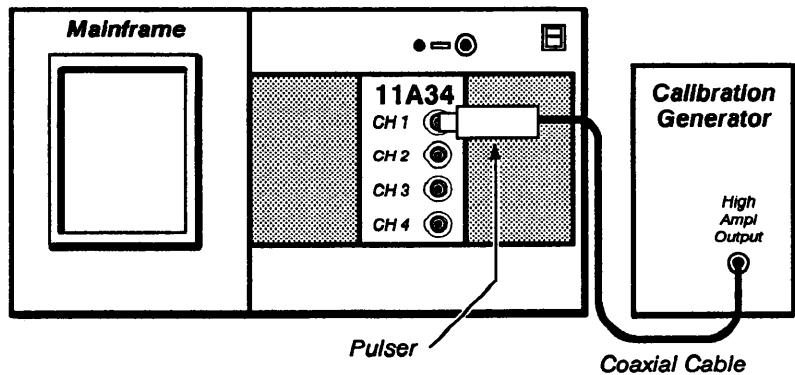

Setup to Examine/Adjust Amplifier Step Response

**Procedure to Examine/Adjust Amplifier Step Response
(A1R1027, A1R1029, A1R1041, A1R1043)**

Step 1: Perform the following settings in the order listed:

- Remove the left side cover from the amplifier.
- Insert the amplifier into the mainframe Center plug-in compartment.
- Connect the pulser to the CH 1 input connector.
- Connect a 50 Ω coaxial cable from the calibration generator High Ampl Output connector to the pulser.

Calibration generator

Function switch High Ampl
 Period 0.1 ms
 Pulse Amplitude Max

Pulser

TD Triggered Level fully clockwise

Mainframe

ON/STANDBY switch ON
 Wait for calibration cycle to complete
 UTILITY major menu Init

Center plug-in

CH 1 Display on/off on

Mainframe

VERTICAL SIZE 50 mV/div
Impedance 50 Ω
 HORIZONTAL SIZE 1 μ s/div
 HORIZONTAL POS position positive-going edge to first
 graticule line from left edge of graticule

Pulser

TD Triggered Level rotate control counterclockwise until the step disappears, then rotate clockwise just enough to obtain a step

Mainframe

HORIZONTAL SIZE 5 ns/div

HORIZONTAL POS position positive-going edge between the first and second graticule lines from the left edge of the graticule

VERTICAL OFFSET position top of step 2.5 divisions above the center horizontal graticule line

VERTICAL SIZE: FINE 5-division step amplitude display

- Step 2: *Examine* that the displayed waveform aberrations are less than 4.5% peak (0.225 division) and 7% peak-to-peak (0.35 division). (You can use Δ Vert cursors to measure this amplitude.)



DO NOT attempt to optimize the aberrations if they are within the stated limits. Proceed to Step 4.

- Step 3: *Adjust* HF1, R1027 on the A1 Main board, so that the aberrations are within 4.5% peak (0.225 division) and 7% peak-to-peak (0.35 division). Refer to Figure 2-1 for adjustment locations.
- Step 4: Remove the displayed waveform.
- Step 5: Move the pulser to the CH 2 input connector. Then, repeat Step 1 beginning at the Center plug-in settings and proceeding through Steps 2, 3, and 4 in this procedure (the adjustment is performed using the HF2 adjustment, R1029).
- Step 6: Move the pulser to the CH 3 input connector. Then, repeat Step 1 beginning at the Center plug-in settings and proceeding through Steps 2, 3, and 4 in this procedure (the adjustment is performed using the HF3 adjustment, R1041).
- Step 7: Move the pulser to the CH 4 input connector. Then, repeat Step 1 beginning at the Center plug-in settings and proceeding through Steps 2, 3, and 4 in this procedure (the adjustment is performed using the HF4 adjustment, R1043).

Setup to Check Amplifier Bandwidth: Performance Verification Procedure

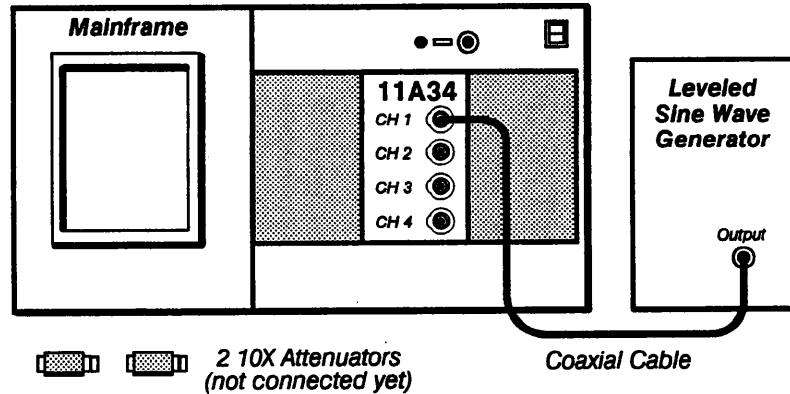

Setup to Check Amplifier Bandwidth: Performance Verification Procedure

Procedure to Check Amplifier Bandwidth: Performance Verification Procedure

Step 1: First **Initialize** the mainframe's settings, then perform the following settings the order listed:

Center plug-in

CH1 Display on/off on
Mainframe

HORIZONTAL SIZE 10 μ s/div

Leveled sine wave generator

Amplitude 4 V p-p

Frequency Ref

If the leveled sine wave generator has a remote leveling head, then you must connect it to the amplifier input connector **without** additional coaxial cables.

The reference frequency must be between 50 kHz and 6 MHz.

Perform this procedure for each Vertical Size listed in column (3) of Table 2-4; then repeat for CH 2.

This procedure may require the use of more than one leveled sine wave generator to test all the frequencies listed in Table 2-4.

If the leveled sine wave generator is not equipped with internal attenuators, then use the 10X Attenuators at the amplifier input when setting amplitude.

To measure the amplitude, either count the divisions or use the Δ V cursors.

Step 2: Set the leveled sine wave generator amplitude as shown in the Reference Amplitude column (4).

Step 3: Set the leveled sine wave generator frequency as shown in the Frequency column (1).

Step 4: Record the Displayed Amplitude in column (5).

- Step 5: Check that the amplifier amplitude, computed by dividing column (5) by column (2), is at least the value shown in column (6).
- Step 6: Set the leveled sine wave generator to the reference frequency.

If there are any failures, the step response must be readjusted for the appropriate deflection factors, so that the Measurement Limits for step response aberrations and the Specifications for bandwidth are both met.

Table 2-4 — 11A34 Amplifier Bandwidth

(1) Test Frequency MHz	(2) Mainframe with Standardizer	(3) Vertical Size	(4) Mainframe with Amplifier				(5) Amplifier only						
			Displayed Amplitude: div	Reference Amplitude: div	Displayed Amplitude: div				Calculated Amplitude: col (5) + col (2)				
					CH 1	CH 2	CH 3	CH 4	CH 1	CH 2	CH 3	CH 4	
250	—	1 V/div	4	—	—	—	—	—	—	>0.546	>0.546	>0.546	>0.546
250	—	500 mV/div	6	—	—	—	—	—	—	>0.818	>0.818	>0.818	>0.818
250	—	50 mV/div	6	—	—	—	—	—	—	>0.818	>0.818	>0.818	>0.818
250	—	20 mV/div	6	—	—	—	—	—	—	>0.818	>0.818	>0.818	>0.818
250	—	10 mV/div	6	—	—	—	—	—	—	>0.818	>0.818	>0.818	>0.818
250	—	5 mV/div	6	—	—	—	—	—	—	>0.821	>0.821	>0.821	>0.821
200	—	2 mV/div	6	—	—	—	—	—	—	>0.803	>0.803	>0.803	>0.803
150	—	1 mV/div	6	—	—	—	—	—	—	>0.790	>0.790	>0.790	>0.790

Setup to Check Amplifier Bandwidth: Functional Test Procedure

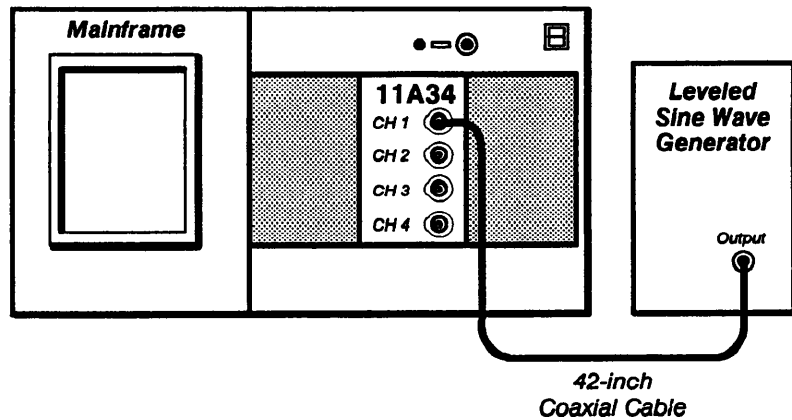

Setup to Check Amplifier Bandwidth: Functional Test Procedure

Procedure to Check Amplifier Bandwidth: Functional Test Procedure

- Step 1: First **initialize** the mainframe's settings, then perform the following settings in the order listed:

Amplifier

CH 1 Display on/off on

Leveled sine wave generator

Frequency Ref (6 MHz)

Mainframe

Impedance 50 Ω

VERTICAL SIZE 200 mV/div

HORIZONTAL SIZE 100 ns/div

- Step 2: Select the CURSORS to measure the peak-to-peak amplitude of the waveform.
- Step 3: Set the leveled sine wave generator for 1.2 V peak-to-peak.
- Step 4: Set the leveled sine wave generator Frequency control to the maximum bandwidth frequency specified for the mainframe-amplifier combination. This limit is displayed as **HF Limit** (VERTICAL SIZE button).
- Step 5: Set the HORIZONTAL SIZE to display several cycles of the waveform.
- Step 6: *Check* that the measurement is at least 848 mV (70.7% of Step 3).
- Step 7: Set the CH 1 display on/off button to off.
- Step 8: Move the coaxial cable to the CH 2 input and set its display on/off to on.
- Step 9: Perform the Steps 1 to 8 for the remaining channels.

Part 4 Overload

This part shows the setup and lists the procedure to check overload.

Specification

Input impedance goes to 1 M Ω .

Setup to Check Overload

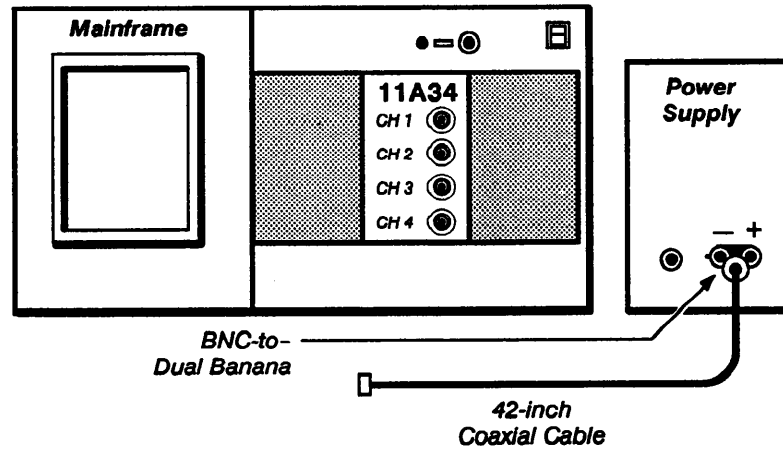

Setup to Check Overload

Procedure to Check Overload

- Step 1: First **Initialize** the mainframe's settings, then perform the following settings in the order listed:

Mainframe	no setting changes
Amplifier	
CH 1 Display on/off	on
Power supply	
Volts	20 V
Current Limit	400 mA

- Step 2: Set **Impedance** to 50 Ω .



*In the following steps, **IMMEDIATELY** disconnect the cable at the input if the impedance does not change within 3 seconds.*

- Step 3: Connect the power supply to the CH 1 input using the 42-inch coaxial cable.
- Step 4: Check that the input impedance goes to 1 M Ω (the current status is shown below the **Impedance** label).
- Step 5: Disconnect the power supply at the input.

- Step 6: Set the Ch 2 display on/off to on.
- Step 7: Repeat Steps 2 through 6 for the remaining input channels.

Part 5
Input Resistance

This part shows the setup and lists the procedure to check input resistance.

Specifications

The specifications for this part are as follows:

- Impedance resistance is 1 M Ω within ± 5 k Ω .
- Impedance resistance is 50 Ω within ± 0.5 Ω .

Setup to Check Input Resistance

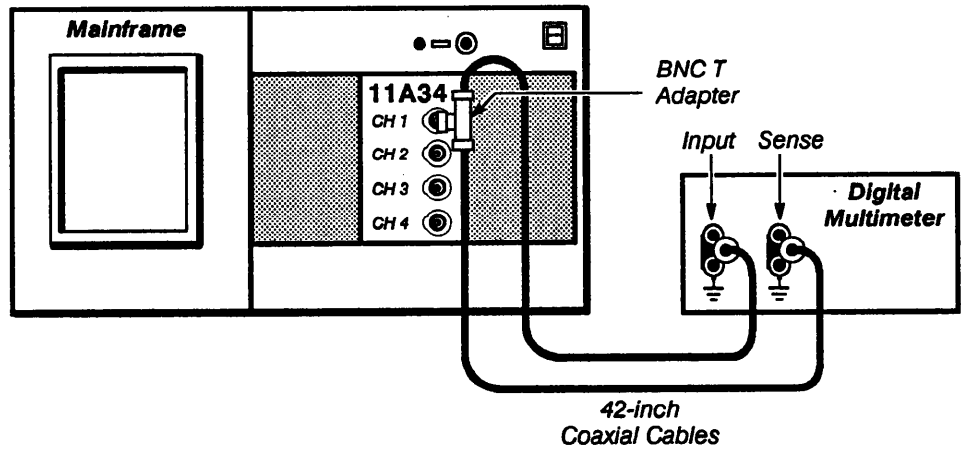

Setup to Check Input Resistance

Procedure to Check Input Resistance

- Step 1: First **Initialize** the mainframe's settings, then perform the following settings in the order listed:

Mainframe no setting changes
 Amplifier
 CH 1 Display on/off on
 Digital multimeter (DMM)
 Resistance mode 4-Wire

- Step 2: Check that the input resistance is 1 M Ω within ± 5 k Ω .
- Step 3: Set CH 1 **Impedance** to 50 Ω .
- Step 4: Check that input resistance is 50 Ω within ± 0.5 Ω .
- Step 5: Repeat Steps 1 through 4 for the remaining input channels.

Part 6 Vertical Accuracy

This part shows the setup and lists the procedure to check vertical accuracy.

Specifications

The specifications for this part are as follows:

- DC balance so that trace is within ± 0.2 divisions of center from 5 mV through 10 V; and ± 1 division of center from 1 mV to 2 mV.
- Peak-Peak measurement of 5 V \pm 90 mV for the 11300-Series and 5 V \pm 57 mV for the 11400-Series.
- DC offset so that the top of the waveform is vertically centered within ± 0.5 divisions.

Setup to Check Vertical Accuracy

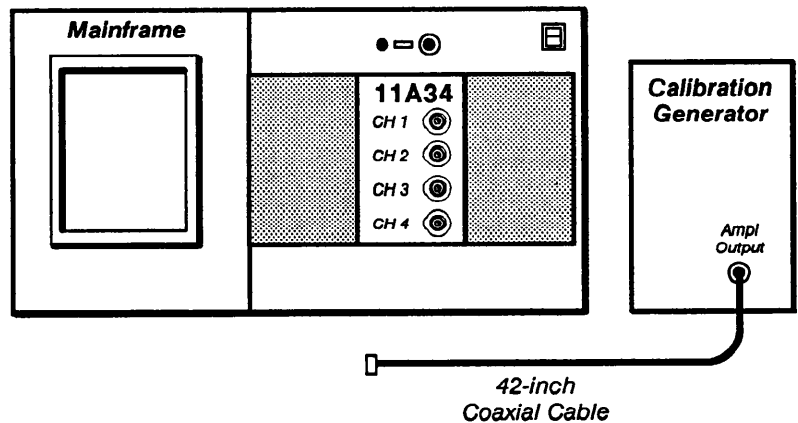

Setup to Check Vertical Accuracy

Procedure to Check Vertical Accuracy

- Step 1: First **Initialize** the mainframe's settings, then perform the following settings in the order listed:

Amplifier

CH 1 Display on/off on

Calibration generator

Mode Std Ampl

Amplitude Output 5 V

Mainframe

Main Size or HORIZONTAL SIZE 100 μ s/div

Average N (if available) On

Check DC Balance – by performing Step 2.

- Step 2: *Check* the Vertical Size to each position from 10 V through 5 mV and observe that the trace stays within ± 0.2 divisions of center. Then, set the Vertical Size to 2 and 1 mV and observe that the trace stays centered within ± 1 division.

Check Gain – by performing Steps 3 through 7.

- Step 3: Connect the calibration generator output to the CH 1 input using the 42-inch coaxial cable.
- Step 4: Set the **Vert Size** or VERTICAL SIZE to 1 V/div.
- Step 5: Set the **Vert Offset** or VERTICAL OFFSET to +2.5 V.
- Step 6: Select the **Peak-Peak** measurement, if available, or the vertical amplitude **Cursors** and measure the peak-to-peak amplitude of the waveform.
- Step 7: *Check* that the measurement is 5 V, plus or minus 90 mV for the 11300-Series mainframe, or 57 mV for the 11400-Series mainframe.

Check Offset – by performing steps 8 through 11.

- Step 8: Set the **Vert Offset** or VERTICAL OFFSET to 5 V.
- Step 9: Set the **Vert Size** or VERTICAL SIZE to 100 mV/div.
- Step 10: *Check* that the top of the waveform is vertically centered within ± 0.5 divisions.
- Step 11: Repeat the Steps 1 through 10 for the remaining channels.

Part 7 Bandwidth Limit

This part shows the setup and lists the procedure to check rise time.

Specifications

The specifications for this part are as follows:

- At a bandwidth limit of 100 MHz, rise time is between 2.45 and 4.55 ns.
- At a bandwidth limit of 20 MHz, rise time is between 12.3 and 22.7 ns.

Setup to Check Bandwidth Limit

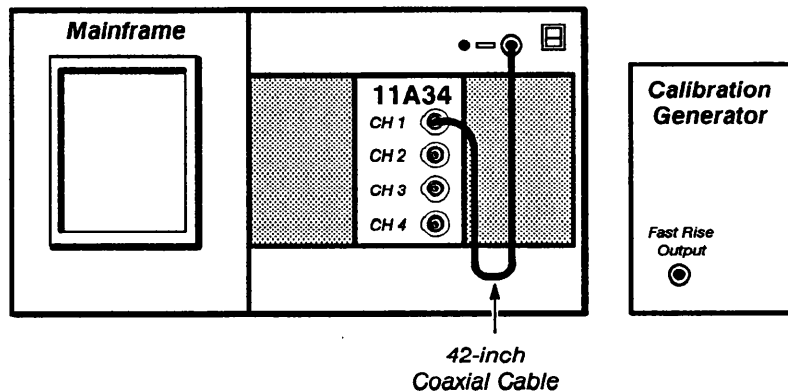

Setup to Check Bandwidth Limit

Procedure to Check Bandwidth Limit

- Step 1: First **Initialize** the mainframe's settings, then perform the following settings in the order listed:

Amplifier

CH 1 Display on/off on

Calibration generator

Period 1 μ s

Mode Fast Rise

Mainframe

Main Size or HORIZONTAL SIZE 5 ns/div

Main Pos or HORIZONTAL POSITION -25.5 ns

- Step 2: On 11400-Series mainframes only, calibrate all input channels by connecting each channel to the CALIBRATOR with the 42-inch coaxial cable and selecting the **Probes** function in the UTILITY major menu.
- Step 3: Connect the calibration generator Fast Rise output (rising edge) to CH 1 with the 42-inch coaxial cable.
- Step 4: Set the **Impedance** to 50 Ω .

- Step 5: Set the **Vert Size** or VERTICAL SIZE to 200 mV/div.
- Step 6: Set the **Vert Offset** or VERTICAL OFFSET to -500 mV.
- Step 7: Set the calibration generator Amplitude to 1 V.
- Step 8: Select 100 MHz bandwidth limit.
- Step 9: Select the **Rise Time** measurement, if available.
- Step 10: *Check* that the rise time is between 2.45 and 4.55 ns.
- Step 11: Set the bandwidth limit to 20 MHz.
- Step 12: *Check* that the rise time is between 12.3 and 22.7 ns.
- Step 13: Set the current input channel display to off.
- Step 14: Set the next channel's display on/off to on.
- Step 15: Repeat Steps 3 through 14 for the remaining channels.

Part 8 AC Coupling

This part shows the setup and lists the procedure to check AC coupling.

Specifications

The specifications for this part are as follows:

- Bottom of square wave is near the bottom graticule line.
- The waveform is approximately centered on the screen.

Setup to Check AC Coupling

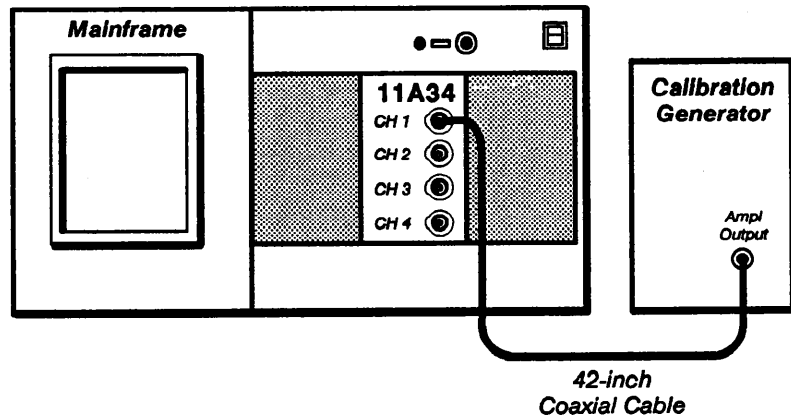

Setup to Check AC Coupling

Procedure to Check AC Coupling

- Step 1: First **Initialize** the mainframe's settings, then perform the following settings in the order listed:

Amplifier

CH 1 Display on/off on

Calibration generator

Mode Std Ampl

Amplitude 5 V

Mainframe

Impedance **50 Ω**

Vert Size or VERTICAL SIZE 500 mV/div

Main Size or HORIZONTAL SIZE 100 μ s/div

- Step 2: Check that the bottom of the square wave is near the center graticule line.
- Step 3: Select AC Coupling for the CH 1 input.
- Step 4: Check that the waveform is approximately centered on the screen (duty cycle will cause some variation).

- Step 5: Set the CH 1 display on/off to off.
- Step 6: Move coaxial cable to the CH 2 input and set its display on/off to on.
- Step 7: Repeat Steps 1 through 6 for the remaining channels.

Part 9 DC Balance

The position of the displayed trace with no input signal applied is examined.

The purpose of this procedure is to confirm that DC balance can be accomplished accurately. This procedure does not test for drift over time or temperature. Therefore, the specifications are more stringent than the specifications in the *11A34 User's Reference Supplement* and this procedure must be performed immediately after Enhanced Accuracy calibration.

Specifications

Refer to Table 2-5.

Setup to Check DC Balance

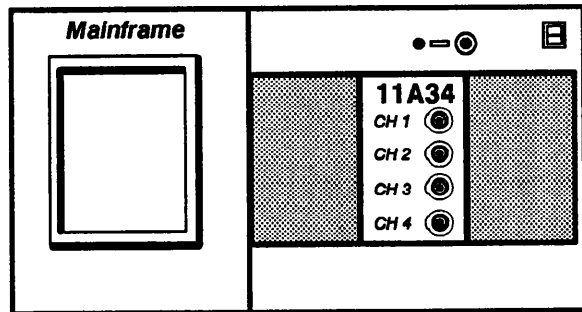

Setup to Check DC Balance

Procedure to Check DC Balance

- Step 1: First **Initialize** the mainframe's settings then perform the following settings in the order listed.

Center plug-in

CH 1 Display on/off on

Mainframe

Vert Size or **VERTICAL SIZE** 10 V/div

BW Limit or **HF Limit** 20 MHz

Impedance 50 Ω

- Step 2: *Check* that the displayed trace position is at the center graticule line, within the value Shift listed in Table 2-5 for each Vert Size setting.

If you are using the 11300-Series mainframe, use **Vertical Cursors** to help measure the trace position.

If you are using the 11400-Series mainframe, set **Average N** to **On** and use **Mean (whole zone)** in the **Measurement** pop-up menu to help measure the trace position.

Repeat Step 2 for each channel.

Table 2-5 – 11A34 Amplifier DC Balance

Vert Size	11400-Series Shift		11300-Series Shift
	(± div)	(± mV)	(± div)
10 V/div	0.063	630	0.093
5 V/div	0.065	330	0.095
2 V/div	0.073	146	0.103
1 V/div	0.085	85	0.115
0.5 V/div	0.065	33	0.095
0.2 V/div	0.073	14.6	0.103
0.1 V/div	0.085	8.3	0.115
50 mV/div	0.065	3.3	0.095
20 mV/div	0.073	1.46	0.103
10 mV/div	0.085	.83	0.115
5 mV/div	0.110	.55	0.140
2 mV/div	0.185	.37	0.215
1 mV/div	0.310	.31	0.340

Part 10a
 ΔV DC Accuracy:
11400-Series
Mainframe Procedure

The system ΔV DC Accuracy is checked using a precision digital multimeter and power supply.

The purpose of this procedure is to confirm that the amplifier can be accurately calibrated. This procedure does not test for mainframe calibration voltage reference accuracy or long term stability. Therefore, the mainframe is characterized and tests must be performed immediately after an Enhanced Accuracy calibration. Also, the amplifier specifications are more stringent than those in the *11A34 User's Reference Supplement*.

Specification

ΔV DC Accuracy within $\pm 0.63\%$.

Setup to Characterize the 11400-Series Mainframe

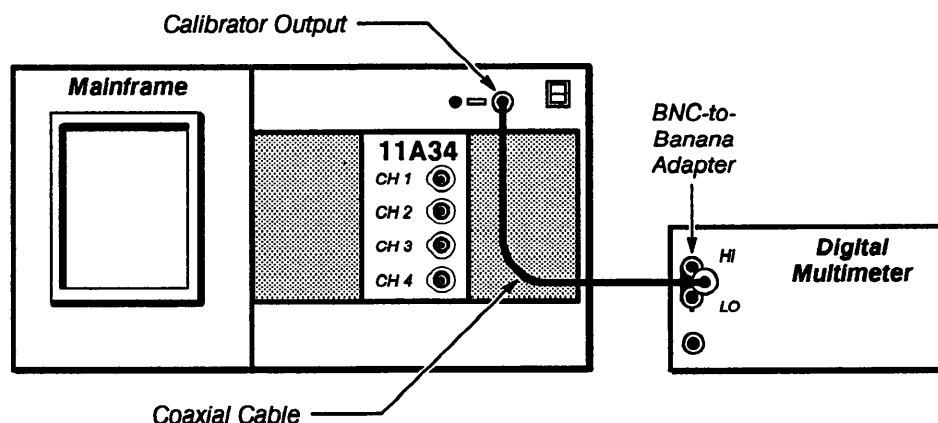

Setup to Characterize the 11400-Series Mainframe

Procedure to Characterize the 11400-Series Mainframe

Step 1: Perform the following settings:

- Center plug-in no setting changes
- Mainframe
 - UTILITY major menu **Extended Diagnostics**
 - Subsystem **Digitizer**
 - Block **Points Acq**
 - Area **Cal Refs**
 - Routine **FP -10.000 V**
 - Run
- Digital multimeter (DMM)
 - Mode DC
 - Range Auto

Step 2: Record the DMM absolute value.

- Step 3: Press **Ext.**
- Step 4: Press **FP + 9.9951 V.**
- Step 5: Press **Run.**
- Step 6: Record the DMM reading.
- Step 7: Press **Ext.**
- Step 8: Press **Exit Diagnostics.**
- Step 9: Add the DMM absolute values of the readings obtained in Steps 2 and 6. Divide the result by 19.9951 V to obtain the mainframe's calibration voltage reference characterization factor (which is used in the Procedure to Test the Amplifier).

Setup to Check the Amplifier ΔV DC Accuracy

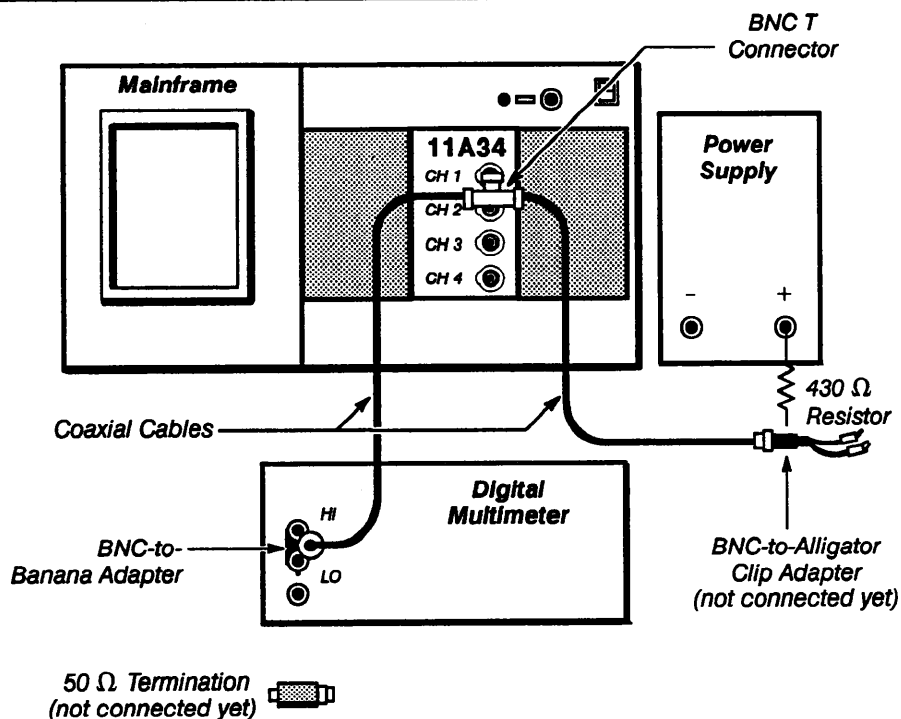

Setup to Check the Amplifier ΔV DC Accuracy

Procedure to Check the Amplifier ΔV DC Accuracy

- Step 1: First **Initialize** the oscilloscope's settings, then perform the following settings in the order listed.

Center plug-in

CH 1 Display on/off on

Mainframe

Vert Size 10 V/div
BW Limit 20 MHz

Power supply

Output on

Digital multimeter (DMM)

Mode DC
Range Auto

If the environment is electrically noisy, then connect a capacitor (at least 0.1 μ F) across the input terminals of the DMM.

Press the Enhanced Accuracy button twice. Immediately after self-calibration has completed and passed, perform this procedure for each channel.

It is helpful if you use a pocket calculator to do the calculations required for evaluating the data in this part. If your DMM is equipped with a comparison or relative reference feature, use this feature for the readings and calculation required in Steps 3 and 5.

When connecting the alligator clips, connect one clip directly to the power supply's negative terminal and the other clip to the 430 Ω resistor (not the power supply's positive terminal).

- Step 2: Set **Average N** to **On**, select **Mean (whole zone)** in the MEASURE major menu, and set **Compare** to **On**.
- Step 3: Connect the alligator clips to the power supply and set the voltage so that the trace is within ± 0.2 division of the first graticule line above the bottom of the screen. Read the DMM and record the absolute value (that is, ignore the polarity).
- Step 4: Select **Save Current Meas Value as References** in the **Compare and Reference** pop-up menu of the MEASURE major menu.
- Step 5: Connect the alligator clips to the power supply and set the voltage so that the trace is within ± 0.2 division of the first graticule line below the top of the screen. Read the DMM and add the absolute value (that is, ignore the polarity) to the reading obtained in Step 3.
- Step 6: Read the Δ **Mean** value in the MEASURE major menu.
- Step 7: Divide the sum obtained in Step 5 by the Δ readout obtained in Step 6. Then, divide this result by the mainframe characterization factor (obtained in Step 9 of the Procedure to Characterize 11400-Series Mainframe).
- Step 8: Check that the result obtained in Step 7 is ≥ 0.9937 but ≤ 1.0063 .

- Step 9:** Repeat Steps 3 through 8 for the vertical size settings listed below. When testing with small voltages, it may help to install a 50 Ω termination and attenuators in series between the BNC-to-alligator clip adapter and the coaxial cable so that you can set the voltages with better resolution. You can also use a DC voltage calibrator to achieve better resolution (when testing with small voltages).

5 V/div
2 V/div
1 V/div
0.5 V/div
0.2 V/div
0.1 V/div
50 mV/div
49.8 mV/div
23 mV/div
20 mV/div
10 mV/div
5 mV/div
2 mV/div
1 mV/div

Part 10b
 ΔV DC Accuracy:
 11300-Series
 Mainframe Procedure

The system ΔV DC Accuracy is checked using a precision digital multimeter and power supply.

The purpose of this procedure is to confirm that the amplifier can be accurately calibrated. This procedure does not test for mainframe calibration voltage reference accuracy or long term stability. Therefore, the mainframe is characterized and tests must be performed immediately after an Enhanced Accuracy calibration. Also, the amplifier specifications are more stringent than those in the *11A34 User's Reference Supplement*.

Specification

ΔV DC Accuracy within $\pm 1.2\%$.

Setup to Characterize the 11300-Series Mainframe

Note: After entering Extended Test, verify that your mainframe's firmware is Version V2.4 or higher. If your mainframe's firmware version is lower than V2.4, then you cannot perform this procedure.

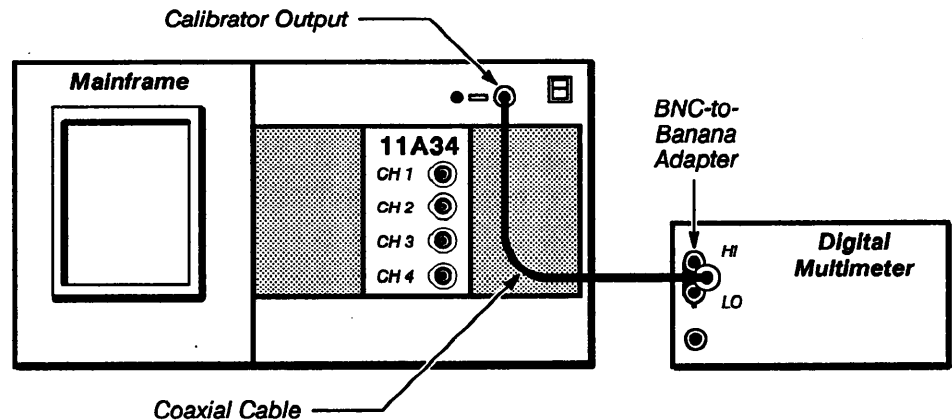

Setup to Characterize the 11300-Series Mainframe

Procedure to Characterize the 11300-Series Mainframe

Step 1: Perform the following settings:

- Center plug-in no setting changes
- Mainframe
- UTILITY major menu Ext Test
- Run
- Block Front Panel
- Area FP Calibrator
- Routine -9.9988 V
- Loop cnt()
- Run

Digital multimeter (DMM)

Mode DC
 Range Auto

- Step 2: Record the DMM reading.
- Step 3: Select Run.
- Step 4: Select Routine and set to +9.9939V.
- Step 5: Select Run.
- Step 6: Record the DMM reading.
- Step 7: Select Run.
- Step 8: Press the UTILITY button.
- Step 9: Add the absolute values of the DMM readings obtained in Steps 2 and 6. Divide the result by 19.9927 to obtain the mainframe's calibration voltage reference characterization factor (which is used in the Procedure to Test Amplifier).

Setup to Check the Amplifier ΔV DC Accuracy

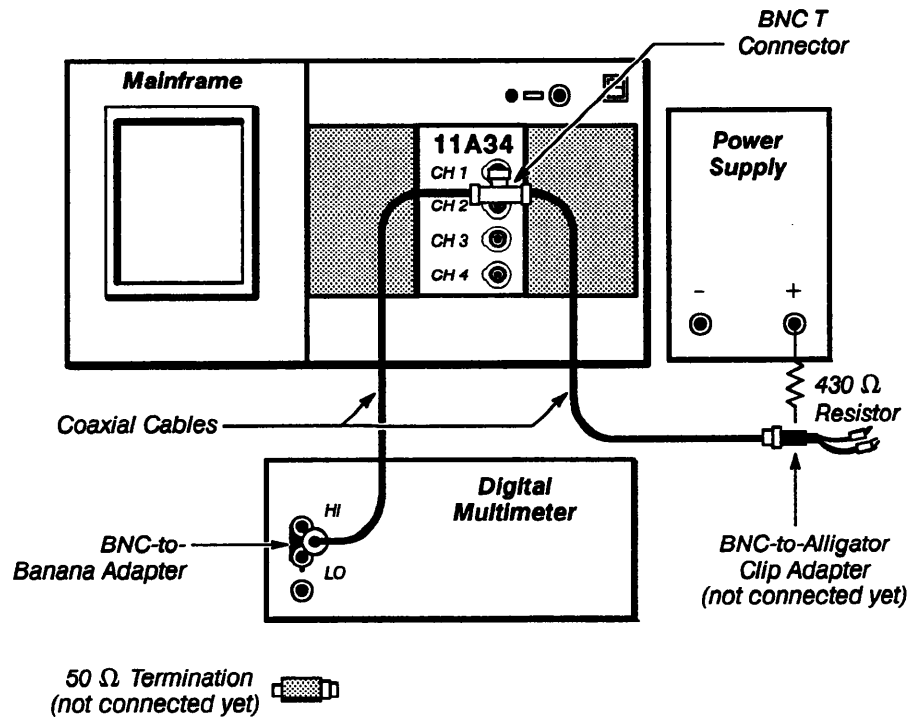

Setup to Check the Amplifier ΔV DC Accuracy

Procedure to Check the Amplifier ΔV DC Accuracy

- Step 1: First **Initialize** the mainframe's settings, then perform the following settings in the order listed.

Center plug-in

CH 1 Display on/off on

Mainframe

HF Limit 20 MHz

Power supply

Output on

Digital multimeter (DMM)

Mode DC

Range Auto

If the environment is electrically noisy, then connect a capacitor (at least 0.1 μ F) across the input terminals of the DMM.

Press the Enhanced Accuracy button twice. Immediately after self-calibration has completed and passed, perform this procedure for each channel.

It is helpful if you use a pocket calculator to do the calculations required for evaluating the data in this part. If your DMM is equipped with a comparison or relative reference feature, use this feature for the readings and calculation required in Steps 3 and 5.

When connecting the alligator clips, connect one clip to the power supply's negative terminal directly and the other clip to the 430 Ω resistor (not the power supply's positive terminal).

- Step 2: Select **Vertical Cursors**.
- Step 3: Connect the alligator clips to the power supply and set the voltage so that the trace is within ± 0.2 divisions of the first graticule line above the bottom of the screen. Read the DMM and record the absolute value (that is, ignore the polarity).
- Step 4: Set the **Vert Ref** cursor on the trace using the left function control knob with FINE resolution.
- Step 5: Connect the alligator clips to the power supply and set the voltage so that the trace is within ± 0.2 divisions of the first graticule line below the top of the screen. Read the DMM and add the absolute value to the reading obtained in Step 3.
- Step 6: Set the Δ Vert cursor on the trace using the right function control knob with FINE resolution. Read the Δ Vert readout.
- Step 7: Divide the sum obtained in Step 5 by the Δ readout obtained in Step 6. Then divide this result by the mainframe characterization factor obtained in Step 9 of the Procedure to Characterize 11300-Series Mainframe.
- Step 8: Check that the result obtained in Step 7 is ≥ 0.988 but ≤ 1.012 .

- Step 9: Repeat Steps 3 through 8 for the vertical size settings listed below. When testing with small voltages, it may help to install a 50 Ω termination and attenuators in series between the BNC-to-alligator clip adapter and the coaxial cable so that you can set the voltages with better resolution. You can also use a DC voltage calibrator to achieve better resolution (when testing with small voltages).

5 V/div
2 V/div
1 V/div
0.5 V/div
0.2 V/div
0.1 V/div
50 mV/div
49.8 mV/div
23 mV/div
20 mV/div
10 mV/div
5 mV/div
2 mV/div
1 mV/div

Part 11 DC Offset Accuracy

The system DC Offset is checked using a precision digital multimeter and a power supply.

The purpose of this procedure is to confirm that the amplifier can be accurately calibrated. This procedure does not test for mainframe calibration voltage reference accuracy or long term stability. Therefore, the mainframe is characterized and tests must be performed immediately after an Enhanced Accuracy calibration. Also, the amplifier specifications are more stringent than those in the *11A34 User's Reference Supplement*.

Specifications

Refer to Table 2-6.

Setup to Characterize the 11400-Series Mainframe

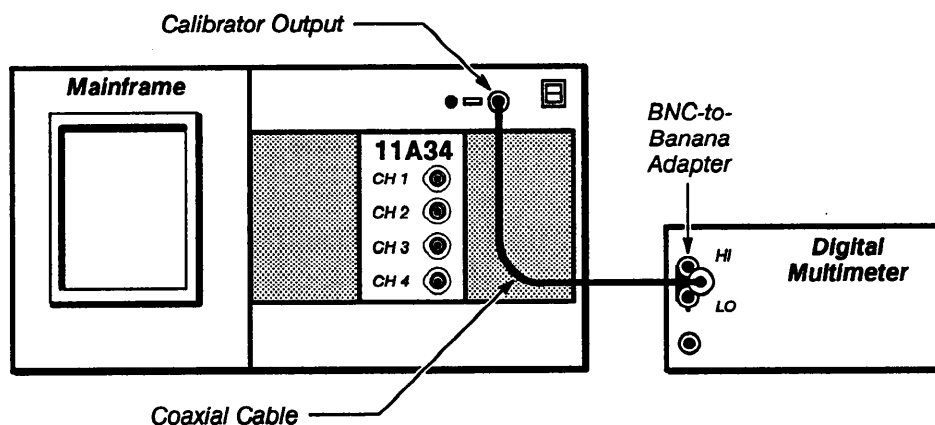

Setup to Characterize the 11400-Series Mainframe

Procedure to Characterize the 11400-Series Mainframe

- Step 1: Perform the following settings:

Center plug-in	no setting changes
Mainframe	
UTILITY major menu	Extended Diagnostic
Block	Points Acq
Area	Cal Refs
Routine	FP -10.000 V
Run	
Digital multimeter (DMM)	
Mode	DC
Range	Auto

- Step 2: Record the DMM absolute value.

- Step 3: Press **Exit**.
- Step 4: Press **FP + 9.9951 V**.
- Step 5: Press **Run**.
- Step 6: Record the DMM reading.
- Step 7: Press **Exit**.
- Step 8: Press **Exit Diagnostics**.
- Step 9: Add the absolute values of the DMM readings obtained in Steps 2 and 6. Divide the result by 19.9951 V to obtain the mainframe's calibration voltage reference characterization factor (which is used in the Procedure to Test the Amplifier).

Setup to Characterize the 11300-Series Mainframe

Note: After entering *Extended Test*, verify that your mainframe's firmware is Version V2.4 or higher. If your mainframe's firmware version is lower than V2.4, then you cannot perform this procedure.

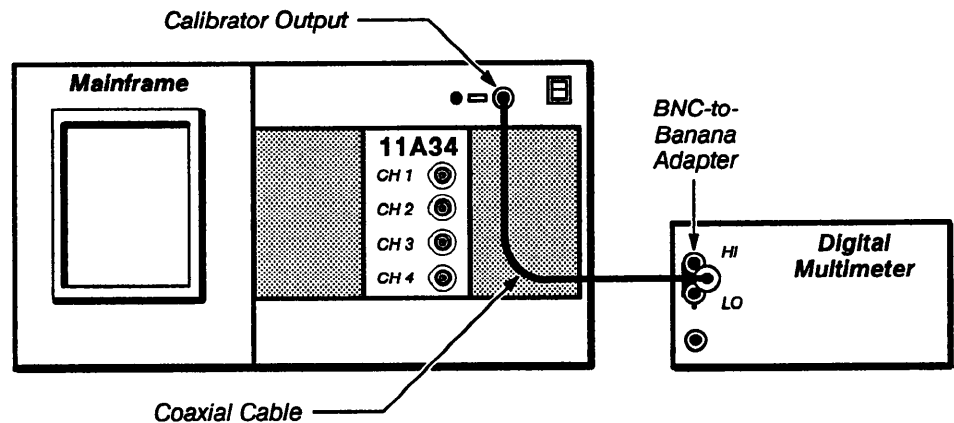

Setup to Characterize the 11300-Series Mainframe

Procedure to Characterize the 11300-Series Mainframe

- Step 1: Perform the following settings:

Center plug-in	no setting changes
Mainframe	
UTILITY major menu	Ext Test
Block	Front Panel
Area	FP Callibrator
Routine	-9.9988 V
Loop	cnt()
Run	

- Step 2: Record the DMM reading.
- Step 3: Select **Run**.
- Step 4: Select **Routine** and set to **+9.9939**.
- Step 5: Select **Run**.
- Step 6: Record the DMM reading.
- Step 7: Select **Run**.
- Step 8: Press the **UTILITY** button.
- Step 9: Add the absolute values of the DMM readings obtained in Steps 2 and 6. Divide the result by 19.9927 to obtain the mainframe's calibration voltage reference characterization factor (which is used in the Procedure to Test the Amplifier).

Setup to Check the Amplifier ΔV DC Offset Accuracy

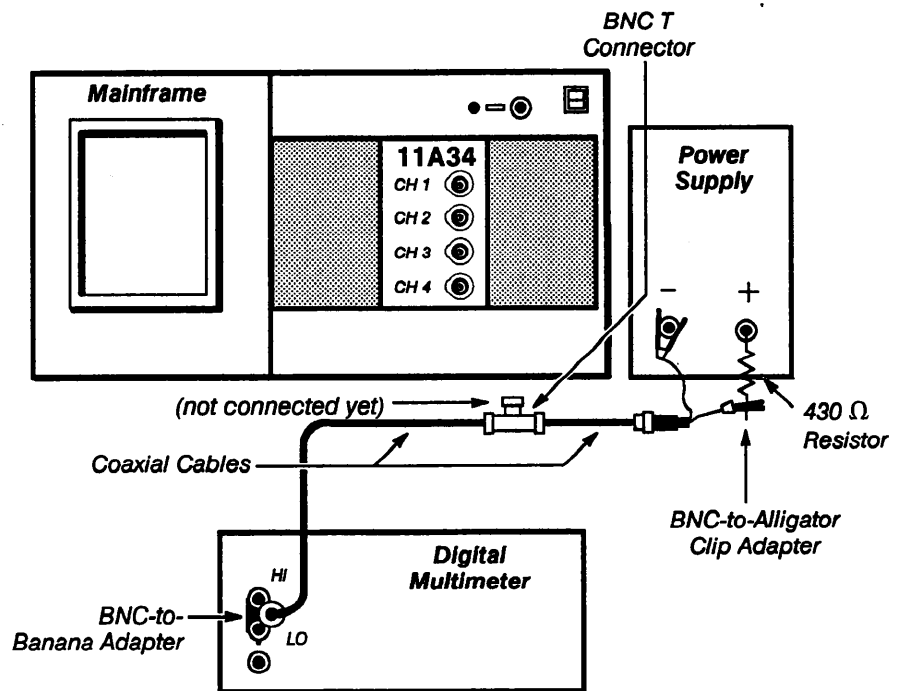

Setup to Check the Amplifier ΔV DC Accuracy

Procedure to Check the Amplifier ΔV DC Offset Accuracy

- Step 1: First **Initialize** the mainframe's settings, then perform the following settings in the order listed:

Center plug-in
 CH 1 Display on/off on
 Mainframe
 BW Limit or HF Limit **20 MHz**
 Power supply
 Output on
 Digital multimeter (DMM)
 Mode DC
 Range Auto

If the environment is electrically noisy, then connect a capacitor (at least 0.1 μ F) across the input terminals of the DMM.

Press the Enhanced Accuracy button twice. Immediately after self-calibration has completed and passed, perform this procedure for each channel.

When connecting the alligator clips, connect one clip directly to the power supply's negative terminal and the other clip to the 430 Ω resistor (not the power supply's positive terminal).

- Step 2: Note the position of the displayed trace (it should be near the center of the graticule).

If you are using the 11300-Series mainframe, use **Vertical Cursors** to help measure and set the trace position.

If you are using the 11400-Series mainframe, set **Average N** to **On** and use **Mean (whole zone)** in the MEASURE major menu to help measure and set the trace position.

- Step 3: Connect the BNC T Connector to the CH 1 input connector, with the DMM connected.
- Step 4: Set the **Vert Offset** or VERTICAL OFFSET to 4 V. Set the power supply voltage so that the displayed trace returns to the position noted in Step 2. Divide the DMM reading by the mainframe characterization factor (obtained in the Procedure to Characterize the Mainframe) and subtract the Vertical Offset.
- Step 5: *Check* that the result obtained in Step 4 is less than the Error Limit shown in Table 2-6.
- Step 6: Disconnect the BNC T connector at the CH 1 input connector and set **Vert Offset** or VERTICAL OFFSET to 0.
- Step 7: Repeat Steps 2 through 6 for each Vertical Size and Offset shown in Table 2-6. When testing with small voltages, it may help to install attenuators in series between the BNC-to-alligator clip adapter and the coaxial cable so that you can set the voltages with better resolution. You can also use a DC voltage calibrator to achieve better resolution (when testing with small voltages).

Table 2-6 – 11A34 Amplifier DC Offset Accuracy

Vertical Size	Vertical Offset	Error Limit (\pm Volts)
1 V/div	4 V	46 mV
0.1 V/div	4 V	10 mV
1 mV/div	1 V	1.4 mV
1 mV/div	800 mV	1.2 mV
1 mV/div	600 mV	1.0 mV
1 mV/div	400 mV	0.8 mV
1 mV/div	200 mV	0.6 mV

Maintenance

This section contains information for performing preventive maintenance, corrective maintenance, and diagnostic troubleshooting on the 11A34 Amplifier. For more information on any equipment listed in this section refer to Table 2-2.

Preventive Maintenance

Preventive maintenance performed regularly can prevent or forestall amplifier breakdown and may improve amplifier reliability. The severity of the environment to which the amplifier is subjected determines the frequency of maintenance.

Amplifier Shield Removal

The side shields, top-and-bottom frames, and front panel reduce radiation of electromagnetic interference (EMI) from the amplifier. The side shields are held in place by grooves in the frame.

To remove a shield, pry it out with your fingers, beginning at the rear of the appropriate side. To install a shield, position it over the frame grooves, then press down with your fingers until the shield snaps into place. Pressure must be applied along the full length of the frames to secure the shield.

The amplifier will not slide into the mainframe if the side shields are not fully seated in the frames.

Cleaning

The amplifier should be cleaned as often as operating conditions require. Accumulation of dirt on components acts as an insulating blanket and prevents efficient heat dissipation, which can cause overheating and component breakdown. Dirt also provides an electrical conduction path that can result in amplifier failure.

The cabinet panels of the mainframe, in which the amplifier is installed, reduce the amount of dust reaching the interior of the amplifier. Keep the cabinet panels in place for safety and cooling.



Avoid the use of chemical cleaning agents which might damage the materials used in this amplifier. Use only Isopropyl alcohol or totally denatured ethyl alcohol. Before using any other type of cleaner, consult your Tektronix service center or representative.

Exterior—dust accumulated on the outside of the amplifier can be removed with a soft cloth or small brush. The brush is particularly useful for dislodging dirt in and around the side-shield ventilation holes and front-panel switches. Remove the side shields before cleaning them.

Interior – cleaning the interior of the amplifier should seldom be necessary. The best way to clean the interior is to blow off the accumulated dust with dry, low-velocity air (such as from a vacuum cleaner). Remove any dirt that remains with a soft brush or a cloth dampened with a mild solution of detergent and water. A cotton-tipped swab is useful for cleaning in narrow spaces, or for cleaning more delicate circuit components (refer to the topic Amplifier Hybrids, under Corrective Maintenance later in this section, for more information on Hypcon connectors).



Circuit boards and components must be dry before applying power to prevent damage from electrical shorts.

Visual Inspection

The amplifier should be inspected occasionally for loosely-seated or heat-damaged components. The corrective procedure for most visible defects is obvious. However, particular care must be taken if heat-damaged parts are found. Overheating usually indicates other problems in the instrument. Therefore, correcting the cause of overheating is important to prevent recurrence of the damage.

Periodic Electrical Adjustment

To ensure accurate measurements, check the electrical adjustment of this instrument after each 2,000 hours of operation, or every 24 months if used infrequently. Instructions are given in Section 2, Checks and Adjustments.

Corrective Maintenance

Corrective maintenance consists of Field Replaceable Unit (FRU) and FRU IC replacement. This section describes the techniques required to replace the FRUs in the amplifier.

Ordering Parts

When ordering replacement parts from Tektronix, Inc., include the following information:

- Amplifier type
- Amplifier serial number
- Description of the part (if electrical, include the circuit number)
- Tektronix part number

Static-Sensitive Device Classification



Static discharge can damage any semiconductor component in this amplifier.

This amplifier contains electrical components that are susceptible to damage from static discharge. Table 3-1 gives relative susceptibility of various classes of semiconductors. Static voltages of 1 kV to 30 kV are common in unprotected environments.

Observe the following precautions to avoid damage:

1. Minimize handling of static-sensitive components.
2. Transport and store static-sensitive components or assemblies in their original containers on a metal surface, or conductive foam. Label any package that contains static-sensitive assemblies or components.
3. Wear a wrist strap while handling these components to discharge the static voltage from your body. Servicing static-sensitive assemblies or components should be performed only at a static-free work station by qualified service personnel. The use of the static control mat and wrist strap is recommended.
4. Allow nothing capable of generating or holding a static charge on your work station surface.
5. Keep the component leads shorted together whenever possible.
6. Pick up components by the body, never by the leads.
7. Do not slide the components over any surface.
8. Avoid handling components in areas that have a floor or work-surface covering capable of generating a static charge.

Table 3-1 – Relative Susceptibility to Damage from Static Discharge

Semiconductor Classes	Relative Susceptibility Levels ¹
MOS or CMOS microcircuits, and discrete or linear microcircuits with MOS inputs (most sensitive)	1
ECL	2
Schottky signal diodes	3
Schottky TTL	4
High-frequency bipolar transistors	5
JFETs	6
Linear microcircuits	7
Low-power Schottky TTL	8
TTL (least sensitive)	9

¹Voltage equivalent for levels.

1 = 100 to 500 V

2 = 200 to 500 V

3 = 250 V

4 = 500 V

5 = 400 to 600 V

6 = 600 to 800 V

7 = 400 to 1000 V (est.)

8 = 900 V

9 = 1200 V

(The voltage equivalent is the voltage discharged from a 100 pF capacitor through a resistance of 100 Ω.)

Removing and Replacing FRUs



To avoid instrument damage, set the mainframe ON/STANDBY switch to STANDBY and remove the amplifier from the mainframe before removing or replacing FRUs.

See Figure 3-1 to determine the location of an FRU.

The exploded-view drawing in Section 5, Replaceable Parts, may also be useful in the removal/replacement procedures that follow.

Note that the side shields will have to be removed to gain access to most of the parts listed in the removal/replacement procedures that follow.



If the green light indicator remains lit when the STANDBY position is selected, then the switch has been left internally disabled after servicing the power supply. To enable the ON/STANDBY switch, refer to the Maintenance section of the mainframe Service Manual.

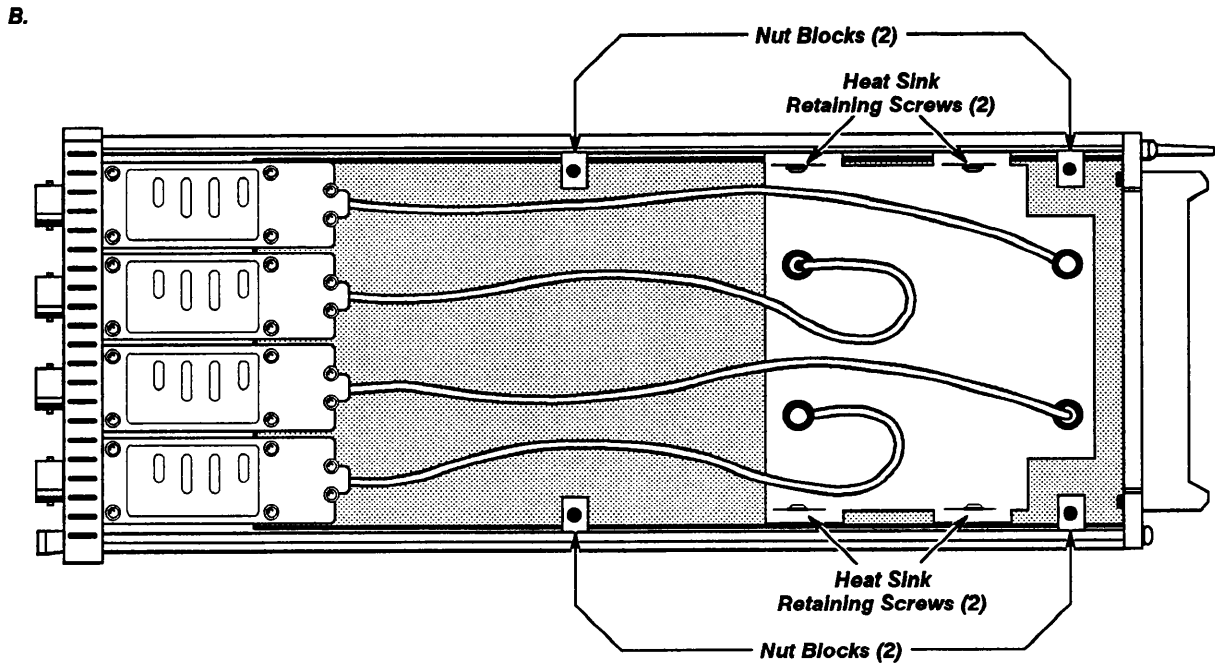
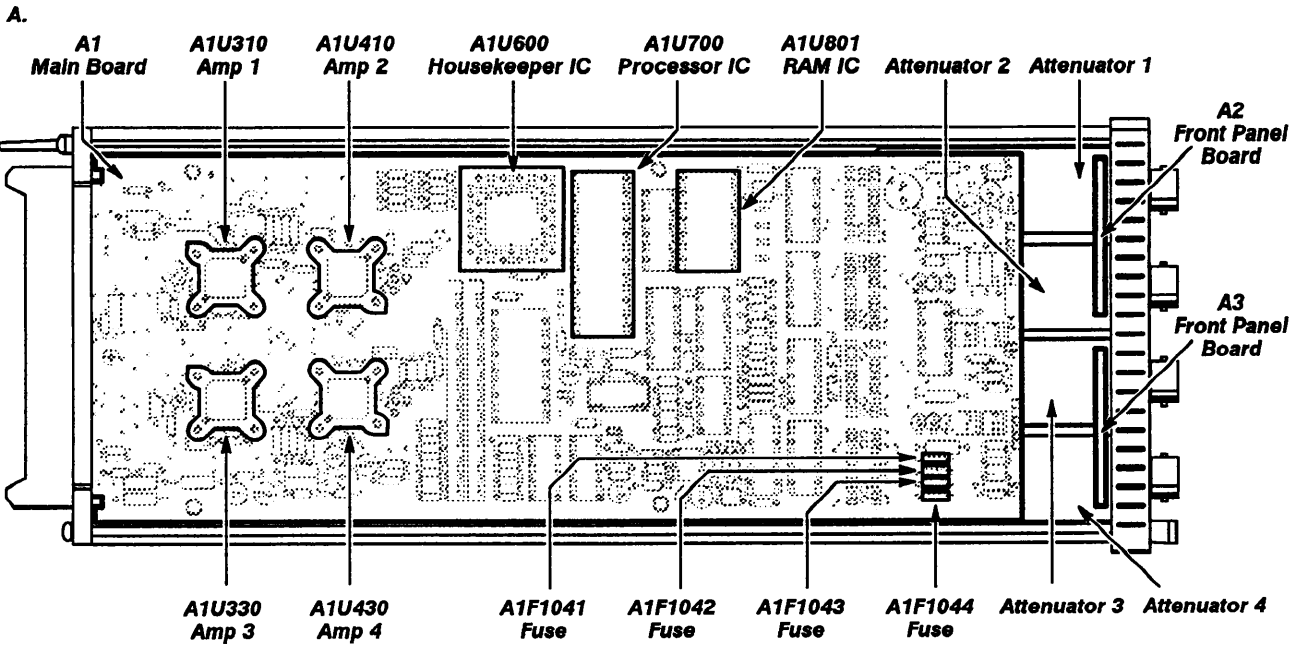

Figure 3-1 – Field Replaceable Units (FRU) Locator and A1 Main Board Securing Hardware

Removing/Replacing FRU ICs



Observe all the special precautions mentioned under the heading, "Static-Sensitive Device Classification," in this section.

Housekeeper Integrated Circuit ("Slam-Pack" ICs) – The Housekeeper IC (A1U600) is indexed to its socket by a beveled corner, as shown in Figure 3-2. The other corners are notched to fit the edges of the socket. The beveled corner aligns with a spring (small metal tab) at one corner of the socket.

Remove the Housekeeper IC as follows:

- Step 1: Unfasten the retaining clip by moving it across the tabs. It may help to push down slightly on the cover.
- Step 2: Remove the cover slowly to prevent the IC from falling out. Observe the index of the IC before removing it.
- Step 3: Remove the IC with tweezers.



Avoid touching the IC or the socket contacts with your fingers. Finger oils can lessen reliability.

Install the Housekeeper IC as follows:

- Step 1: Using tweezers, place the beveled corner of the replacement IC against the index spring.



Do not damage the spring with the beveled corner. Shorting of the two corner contacts could result.

- Step 2: Arrange the other IC corners, with the tweezers, to fit evenly at the edges of the socket.
- Step 3: Set the cover flat on the IC with its end tabs properly aligned with the mating recesses in the socket. (The cover is not symmetrical.)
- Step 4: Push the cover down, keeping it flat on the IC, and slide into place. Hold the cover in place while moving the retaining clip over the tabs on the other end.

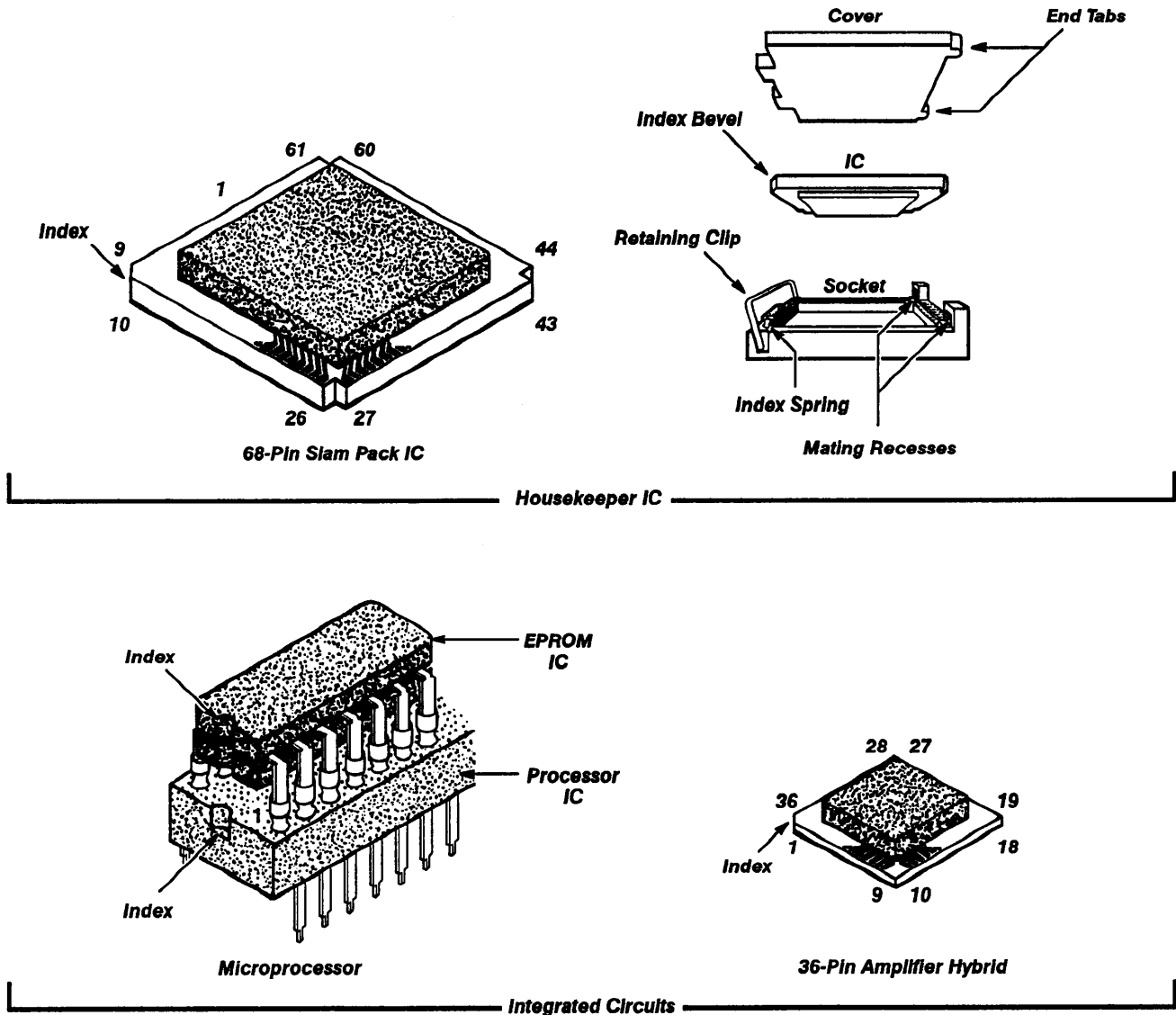

Figure 3-2 — Semiconductor Indexing Diagram

Amplifier Hybrids—Figure 3-3 shows an exploded view of the Hypcon (Hybrid-printed circuit connector) and gives disassembly and replacement instructions. When replacing the hybrid, do not touch the elastomer's gold-plated contacts with your fingers. Use a cleaner which will not lessen contact reliability. The Hypcon socket contacts are fragile. Use caution when removing and replacing a Hypcon to avoid damaging these contacts.

Before reinstallation, use a 4X (or greater) magnifying glass to examine the hybrid, elastomer, and the Hypcon contacts under light for dust, hair, lint, etc. If the etched circuit board surfaces require more cleaning, scrub with a soft rubber eraser. Blow or vacuum clean, while dusting the surface with a small clean brush.

If the hybrid and elastomer contact holder are contaminated, clean them by flushing or spraying with alcohol. **Do not scrub with a cotton-tipped swab or similar device.** (Cotton fibers may adhere to the contacts.) If the contact holder is excessively contaminated, replace it with a new one.

Tighten the mounting screws with two inch-pounds of torque (2.3 centimeter-kilograms) to secure the Hypcon to the circuit board.

Make sure that the elastomer is properly seated in the contact holder before remounting the assembly to the circuit board. Use care when mounting the whole assembly to the circuit board to prevent misalignment between the connector and board.



Because of close tolerances involved, special care must be taken to ensure correct index alignment of each Hypcon part during reassembly. (Fig. 3-3 shows the index locations.) Failure to do so can result in a cracked hybrid substrate.

Removing/Replacing the U350 Hypcon Assembly

When replacing the Hypcon (Hybrid-printed circuit connector) do not touch the elastomer's gold-plated contacts with your finger: instead, use a cleaner which will not lessen contact reliability. The Hypcon socket contacts are fragile. Therefore, refer to the cautions that follow, when removing and replacing a Hypcon, to avoid damaging these contacts.

Before remounting the Hypcon assembly, use a 4X (or greater) magnifying glass to examine the hybrid, elastomer, and the Hypcon contacts for dust, hair, lint, or other foreign matter. If the A1 Main board surfaces require more cleaning, then scrub the surface with a soft rubber eraser and blow on, or vacuum, the surface while dusting it with a small clean brush.

If the hybrid and elastomer contact holders are contaminated, then flush or spray the holders with alcohol.



Do not scrub with a cotton-tipped swab or similar device, since cotton fibers may adhere to the contacts.)

If the contact holder is excessively contaminated, then replace the holder.

Next, tighten the mounting screws with two inch-pounds of torque (2.3 centimeter-kilograms) to secure the Hypcon to the board.

Ensure that the elastomer is properly seated in the contact holder before remounting the assembly to the A1 Main board. (That is, use care when mounting the assembly to the board to ensure that the proper alignment exists between the connector and A1 Main board.)



Special care must be taken to ensure correct index alignment of each Hypcon part during reassembly; since failure to do so can result in a cracked hybrid substrate.

See Figure 3-3 for indexing information.

Remove the Hypcon assembly as follows:

- Step 1: Notice the index on the A1 Main board (arrow) and the plastic frame (pointed tab).
- Step 2: Unscrew and remove the four Torx head screw/washer assemblies.
- Step 3: Lift the plastic frame from the A1 Main board.
- Step 4: Notice the index location of the hybrid, and remove the hybrid from A1 Main board with the tweezers.

Note: Step 5 describes the removal of the elastomer from the plastic frame. This step is unnecessary when replacing the hybrid only.

- Step 5: Notice the index location of the elastomer (contact holder). Grasp and lift the corner of the contact holder with the tweezers to remove the holder from the plastic frame. (Do not touch the gold-plated contacts with your fingers.)

Replace the Hypcon Assembly as follows:

- Step 1: Grasp a corner of the elastomer with the tweezers, and place the elastomer into the plastic frame.
- Step 2: Align the keyed corner of the elastomer with the keyed corner of plastic frame.
- Step 3: Tamp the elastomer into the plastic frame uniformly.

Note: Keeping the elastomer clean is very important. Small hairs and elastomer flash under the contacts, which are almost invisible to the naked eye, can prevent good electrical contact. Most apparent failures of the hybrid are actually due to contamination of the Hypcon. Therefore, do not touch the gold-plated contacts with your fingers.

- Step 4: Place the hybrid into the square hole in the A1 Main board. (The hybrid is keyed so that it will fit into the A1 Main board in only one orientation. When the back of the hybrid rests on the heat sink pedestal, the top of the hybrid should be flush with the top of the A1 Main board.)
- Step 5: Place the plastic frame, with the elastomer installed over the hybrid, so that the key (pointed tab) aligns with the corner arrow on the board.
- Step 6: Replace the four Torx head screw/washer assemblies, and apply two inch-pounds of torque, (2.3 cm-kg) to secure the connector assembly. Do not overtighten the assembly; since over-tightening the assembly will strip the microcircuit stiffener/heat sink mounting threads.

Exploded View of Hypcon Connector

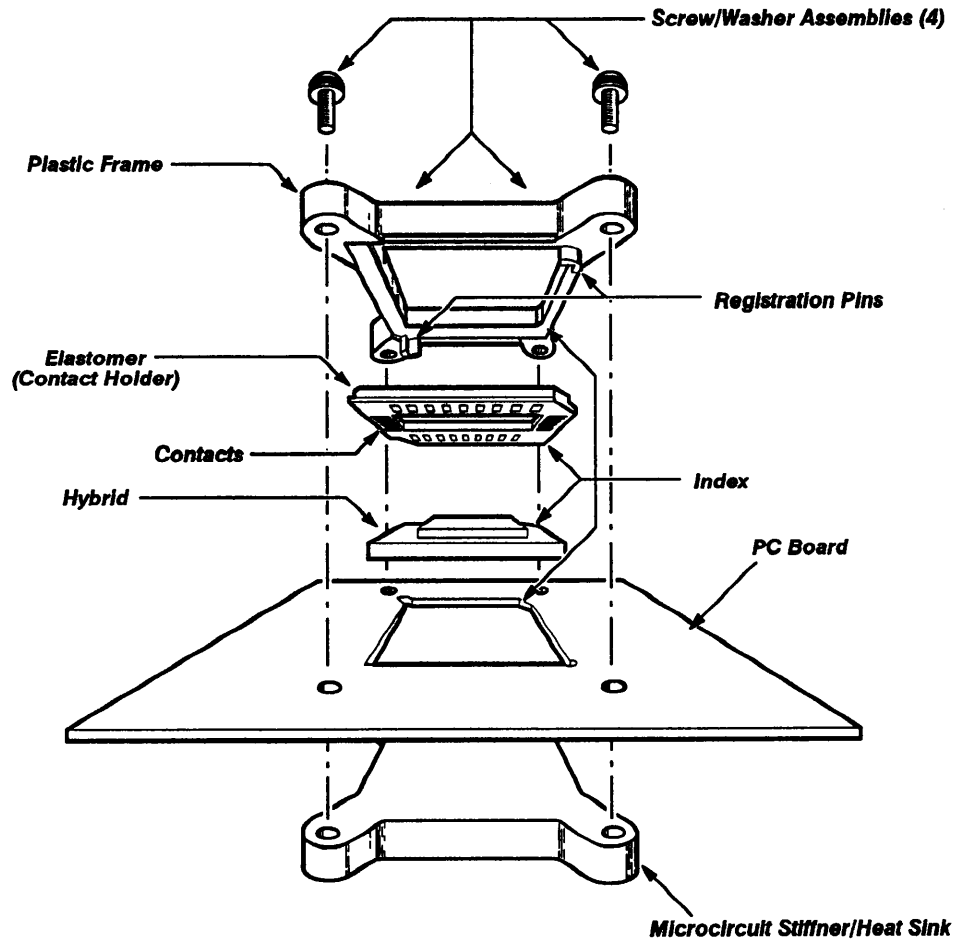

Cross Section View of Hypcon Connector

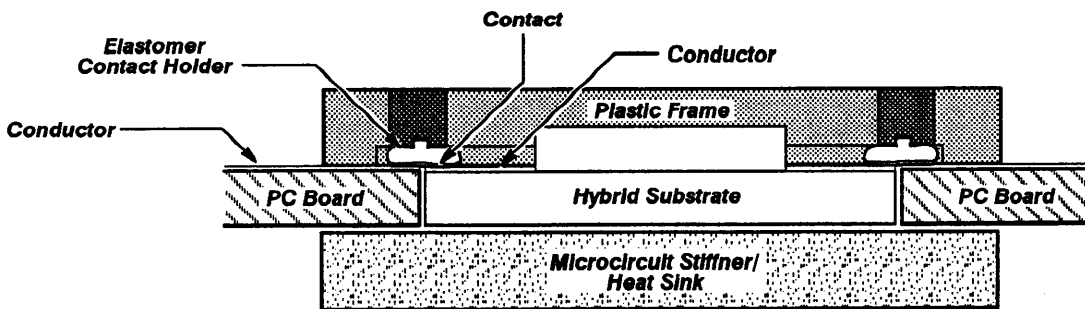

Figure 3-3 – Hypcon Assembly Removal and Replacement

RAM IC—If the RAM IC is soldered into the board, then consult a Tektronix service center for recommended removal procedures. Do not solder in the replacement IC. Instead, install a 24-pin socket and plug the RAM IC into the socket.

EPROM IC –**CAUTION**

Do not remove the label affixed to the top of EPROMs. Removing this label will allow light into the chip, and may cause partial erasure of its data.

The EPROM IC is mounted on top of the Processor on the A1 Main board. (See Fig. 3-1 for the location of this IC.)

Remove the EPROM IC as follows:

- Step 1: Use Insertion-Extraction Pliers (such as General Tool's Part Number U505BG, a 28-pin type) to remove the IC. An illustration of the pliers is shown in Figure 3-4.
- Step 2: Position the pliers around the outside of the IC. Squeeze the handles to grasp the IC and slowly pull it from the socket.

CAUTION

Avoid touching the removed IC pins or socket contacts with your fingers. Finger oils can lessen contact reliability.

Install the EPROM IC as follows:

- Step 1: Grasp the IC with the Insertion-Extraction Pliers. Check that all the IC pins are straight and evenly spaced.
- Step 2: Do not use the IC label as an index. Look for the index on the IC body. Align the index slot with that of the A1U700 Processor IC underneath it. (Figure 3-2 gives an illustration of this indexing.)
- Step 3: Align the pins with their respective socket contacts and slowly seat the IC.

Note: *The Unit Identification (UID) is identical to the amplifier's serial number and is stored in NV RAM. If the EPROM is replaced it is necessary to enter a UID number. The amplifier's UID must be re-entered to generate and store the checksum. Failure to re-enter the UID will result in the "serial number" diagnostic failure during power-up self testing. Entry of the UID is described in this section, refer to Programming The Unit Identification.*

Processor IC – The Processor IC (A1U700) is located on the A1 Main board. See Figure 3-1 for its location. The EPROM IC is mounted on top of the Processor IC.

Remove the Processor IC as follows:

- Step 1: Remove the EPROM IC. Follow the removal instructions given in the preceding part of this section.
- Step 2: Use Insertion-Extraction Pliers (such as General Tool's Part Number U505BG, a 28-pin type) to remove the Processor IC.
- Step 3: Position the pliers around the outside of the IC. Squeeze the handles to grasp the IC and slowly pull it from the socket.

CAUTION

Do not damage the EPROM sockets with the pliers. Avoid touching the IC pins or the socket contacts with your fingers. Finger oils can lessen contact reliability.

Install the Processor IC as follows:

- Step 1: Grasp the replacement IC with the Insertion-Extraction Pliers. Check that all its pins are straight and evenly spaced.
- Step 2: Align the index slot on the IC with the corresponding index on its socket.
- Step 3: Align the IC pins with their respective socket contacts. Push down slowly and evenly on the IC to seat it.
- Step 4: Replace the EPROM IC on top of the Processor IC. Follow the EPROM replacement instructions given in the preceding part of this section.

Note: *The Unit Identification (UID) is identical to the amplifier's serial number and is stored in NV RAM. If the EPROM is replaced it is necessary to enter a UID number. The amplifier's UID must be re-entered to generate and store the checksum. Failure to re-enter the UID will result in the "serial number" diagnostic failure during power-up self testing. Entry of the UID is described in this section, refer to Programming The Unit Identification.*

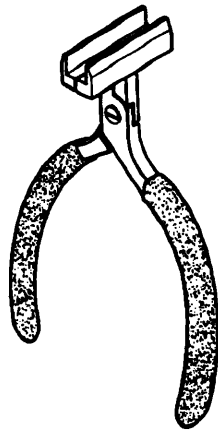

Figure 3-4 – IC Insertion-Extraction Pliers

Circuit Board and Attenuator FRU Removal

Remove the Front Panel as follows:

- Step 1: Unhook the return spring from the release bar, and set it aside.
- Step 2: Use a Torx T-8 screwdriver to remove the four screws that fasten the front subpanel to the top and bottom frames.
- Step 3: Pull the release bar as far out of the instrument as it will come, and leave it in that position.
- Step 4: Insert a slender, sharp-pointed tool, such as a scribe, between the front panel and the subpanel at the notch around the release bar. Gently separate the front panel from the subpanel. Use care to prevent bending the front panel.

Install the Front Panel as follows:

- Step 1: Check that the four screws that fasten the front subpanel to the top and bottom frames are removed.
- Step 2: Check that the release bar return spring is removed.
- Step 3: Set the amplifier on its side with the front panel facing you.
- Step 4: Pull the release bar as far out of the instrument as it will come, and leave it in that position.
- Step 5: Position the front panel so that the notch in the bottom fits over the release bar, then carefully insert the four front-panel tabs into the slots in the front subpanel. (You may need to pull the top and bottom frames away from the subpanel to allow the front-panel tabs to fit between the casting and the frames.)
- Step 6: Gently snap the edges of the front panel into place around the input connectors and the outer edges of the panel.
- Step 7: Use a Torx T-8 screwdriver to install the four screws that fasten the front subpanel to the top and bottom frames.
- Step 8: Install the release bar return spring. Orient the spring so that its loop fits over the frame hook correctly (flat against the frame section).

Remove and Install an A2 or A3 Front Panel Board as follows:

- Step 1: Remove the front panel.
- Step 2: Unplug the connector that provides electrical connection to the A1 Main board.
- Step 3: Use a Torx T-6 screwdriver to remove the two screws that fasten the A2 or A3 Front Panel board to the front subpanel, and remove the A2 or A3 Front Panel board.
- Step 4: To replace an A2 or A3 Front Panel board, follow the preceding steps in reverse order.

Remove an Attenuator as follows: (the Attenuators are identical)

- Step 1: Remove the front panel.
- Step 2: Unplug the cable that connects the attenuator to the A1 Main board.
- Step 3: Use a Torx T-8 screwdriver to remove the two screws from the component side of the A1 Main board that fasten the subject attenuator (refer to Fig. 3-5).
- Step 4: Set the amplifier on its side with the attenuator bodies up.
- Step 5: Use a Torx T-6 screwdriver to remove the four screws that fasten the front of the attenuator to the front subpanel.
- Step 6: Lift up the rear end of the attenuator about 1/4-inch from the board then carefully withdraw the attenuator from the instrument.
- Step 7: Note that the two metal-on-elastomer (MOE) strips are sitting free in the MOE holder.

Install an Attenuator as follows

- Step 1: Set the amplifier on its side with the pushbuttons down.
- Step 2: Put a metal-on-elastomer (MOE) strip holder on the Main board in the appropriate location (refer to Fig. 3-5).
- Step 3: Put the two new MOE strips in the holder. The exposed elastomer side of each strip should face the center of the holder.
- Step 4: Insert the BNC end of the attenuator through the hole in the front subpanel, then let it rest on the A1 Main board.
- Step 5: While holding the attenuator against the MOE assembly, turn the amplifier so that you can install the two screws that fasten the attenuator to the A1 Main board. These screws require a Torx T-8 screwdriver; **do not tighten them yet.**
- Step 6: Use a Torx T-6 screwdriver to install the four screws that fasten the attenuator to the front subpanel.
- Step 7: If presently installed, remove the four screws that fasten the top and bottom frames to the front subpanel.
- Step 8: Install the front panel.
- Step 9: Tighten the screws you installed in step 5.
- Step 10: Reattach the cable that connects the attenuator to the A1 Main board. Figure 3-1 shows the proper connection of the attenuator cables and the receptacles.

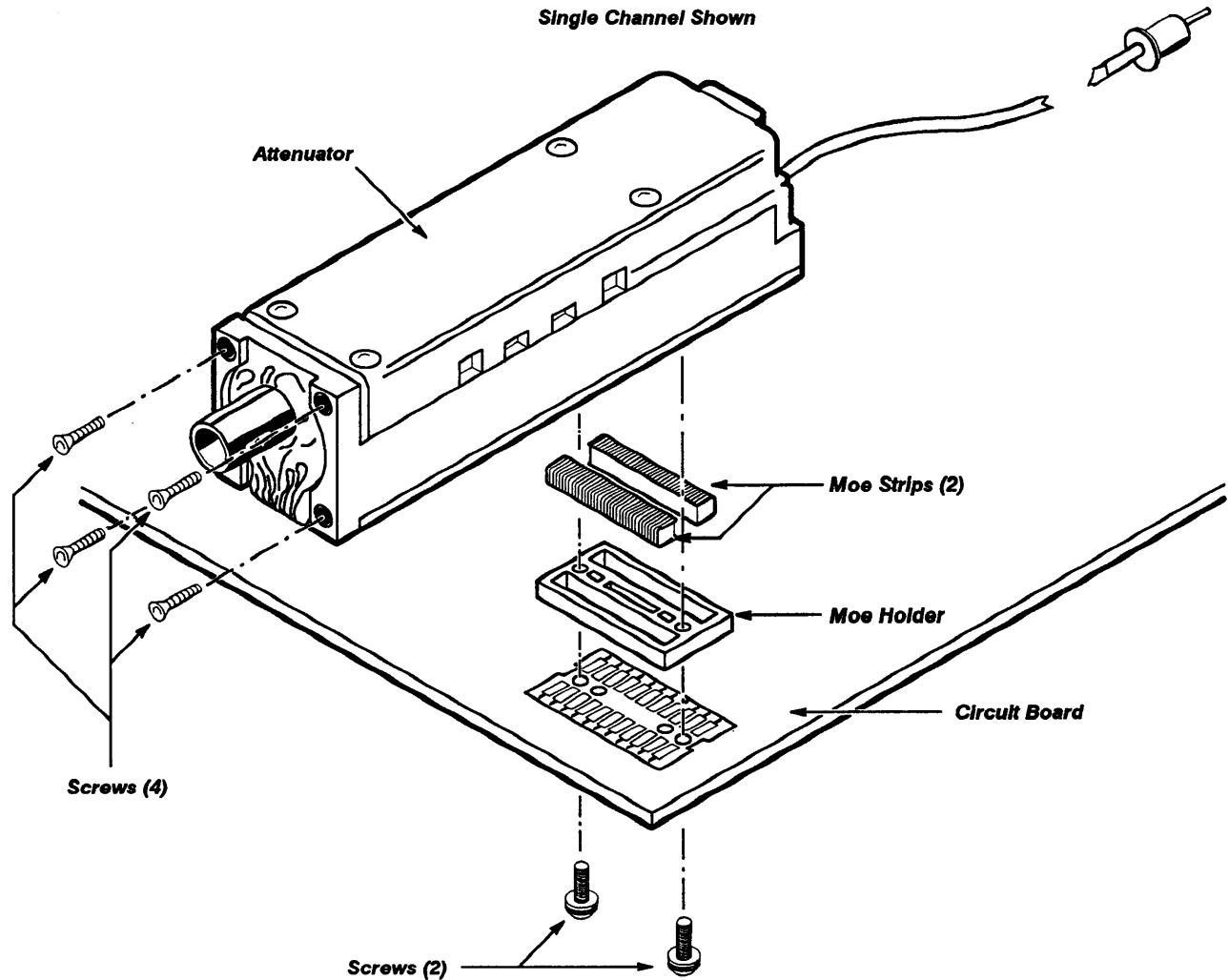

Figure 3-5 – Location of Screws and Parts for Removal of an Attenuator

Remove the A1 Main Board as follows:

- Step 1: Unplug the connector(s) from the Front Panel board(s) at the A1 Main board.
- Step 2: Use a Torx T-8 screwdriver to remove the screws attaching the attenuators to the A1 Main board.
- Step 3: Unplug the cables that connect the attenuators to the A1 Main board.
- Step 4: Unhook the return spring from the release bar.
- Step 5: Use a Torx-8 screwdriver to remove the four screws that fasten the front panel to the top and bottom frames.
- Step 6: Remove the front panel and attenuators.
- Step 7: Remove the metal-on-elastomer (MOE) strips and holders.

- Step 8: Use a Torx T-15 screwdriver to remove the screws that attach the heat sink bracket to the A1 Main board.
- Step 9: Use a Torx T-10 screwdriver to remove the five screws and nut blocks that secure the A1 Main board to the top and bottom frames. Figures 3-1 and 3-6 show the nut blocks. Use a screwdriver with a narrow shaft because the screws have very little offset from the top and bottom frames.
- Step 10: Use a Torx T-15 screwdriver to remove the four screws that fasten the plastic rear panel to the top and bottom frames.
- Step 11: Carefully withdraw the A1 Main board from between the frames.
- Step 12: Remove the rear panel from the A1 Main board.

Install the A1 Main Board as follows:

- Step 1: Align the notches in the rear panel with the notches in the top and bottom frames. Reattach the rear panel to the replacement A1 Main board.
- Step 2: Carefully insert the A1 Main board between the frames until the plastic rear panel contacts the top and bottom frames. The board fits on the top of the center ridges of the top and bottom frames.
- Step 3: Use a Torx T-15 screwdriver to start the four screws that fasten the rear panel to the top and bottom frames.
- Step 4: Use a Torx T-10 screwdriver to start the five screws and nut blocks that clamp the A1 Main board to the top and bottom frames.
- Step 5: Use a Torx T-15 screwdriver to start the screws fastening the heat sink bracket to the A1 Main board.
- Step 6: Tighten the screws that you installed in steps 3, 4, and 5.
- Step 7: Replace the MOE holders on the bottom of the A1 Mother board and put MOE strips in the holders as shown in Figure 3-5.
- Step 8: Slide the front panel and attenuator assembly into position, being careful not to dislodge the MOE strips or holders.

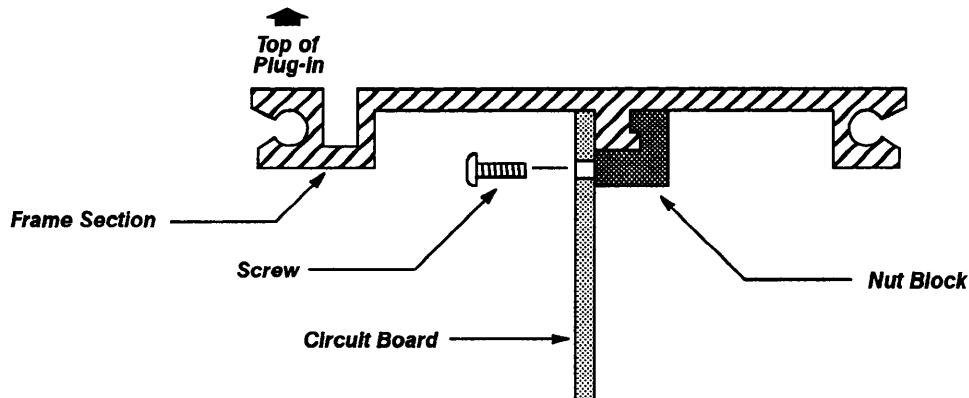

Figure 3-6 — Location of a Nut Block Securing the Circuit Board to the Frame Section

- Step 9: Hold the attenuators against the MOE strips and start all of the screws which attach the attenuators to the A1 Main board.
- Step 10: Use a Torx T-8 screwdriver to install the four screws that fasten the front panel to the top and bottom frames.
- Step 11: Use a Torx T-8 screwdriver to tighten the screws installed in step 9.
- Step 12: Connect the cable(s) from the A2 Front Panel board to the receptacle(s) on the A1 Main board.
- Step 13: Install the release bar return spring. Orient the spring so that its loop fits over the frame hook correctly (flat against the frame section).
- Step 14: If the A1 Main board has been replaced, then the Unit Identification (UID) number needs to be re-entered. Refer to instructions in Programming The Unit Identification later in this section.

Programming The Unit Identification

The Unit Identification (UID) is identical to the instrument's serial number and is stored in NV RAM. It is necessary to enter this number if the A1 Main board is replaced or if data in NV RAM becomes corrupted. If confirmation only of the UID is needed, then use the following procedure except skip step 4.

To enter the UID, use this procedure:

- Step 1: Connect a Terminal to the mainframe's RS-232-C port. (Refer to the mainframe User's Reference Manual for instructions on setting up the RS-232-C parameters.)
- Step 2: Inside the amplifier, move the jumper J611 (shown in Fig. 3-1) on the A1 Main board. The jumper should be vertical in its normal position. Remove the jumper and install it horizontally.
- Step 3: Install the amplifier into any compartment. Turn the power on. Wait until the Diagnostics checks are completed.
- Step 4: At the Terminal, type the command:

UID [Left | Center | Right]: " < Serial Number > "
 - Left | Center | Right refers to the name of the compartment.
- Step 5: At the Terminal, type the query:

UID? [Left | Center | Right]

Observe that the correct UID is reported.
- Step 6: Set the ON/STANDBY switch to STANDBY.
- Step 7: Remove the amplifier.

- Step 8: Reinstall the jumper J611 to its vertical position on the A1 Main board.

Multi-Pin Connectors

Pin 1 on a multi-pin connector is designated with a triangle (or arrowhead) on the holder. A square pad on the circuit board denotes pin 1. When a connection is made to a circuit board, the indexing of the triangle on the multi-pin holder is determined by the square pad.

The multi-pin connector is keyed by a gap between pins 1 and 3 in the holder. (A small plastic plug covers the pin 2 position on the end of the holder.) There is a corresponding gap between pins 1 and 3 on the circuit board as shown in Figure 3-7. The female connector is illustrated by this view. (The male connector also has a similar pin arrangement, but it is not shown.)

Align the holder plug with the gap between the circuit board pins. The connector is then ready to be installed.

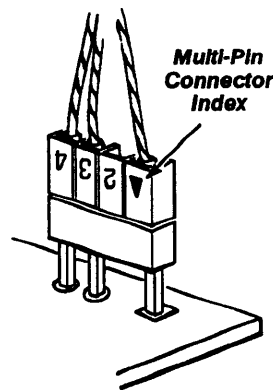

Figure 3-7 – Indexing of Multi-pin Connectors

Diagnostic Troubleshooting

This section provides the information necessary to troubleshoot a faulty instrument to the Field Replaceable Unit (FRU) level. FRUs are circuit boards, attenuator modules, and integrated circuits or hybrids that are replaceable without soldering. The primary means for troubleshooting is to use the error index code output from the Diagnostics or Self-Tests and cross-reference them to the suspect FRU(s) in the FRU Guide tables. After an FRU is replaced, some recalibration of the instrument is normally required (this is discussed further below).

Diagnostics Overview

The processor runs a set of Kernel Tests prior to the Self-Tests. If this is successful, then the Self-Tests run to verify the functionality of each of the subsystems. Any failure causes the instrument to enter Extended Diagnostics and to display the error index code(s) in a diagnostic menu. Extended Diagnostics tests are a superset of the Self-Tests.

The Kernel Tests and Self-Tests/Extended Diagnostics produce and format error index codes differently, so they are covered separately.

Some of these tests that may indicate faulty FRUs are not run automatically during the Self-Tests (that is, some error codes are only generated by manually selecting tests).

The next two subsections provide a quick overview of Kernel Tests and Extended Diagnostics.

Kernel Diagnostics—Each time the front-panel ON/STANDBY switch is set to ON, the mainframe and amplifiers perform Kernel Tests on their microprocessor subsystems and Self Test Diagnostics on all of their major circuits.

CAUTION

Turning the instrument power off during the execution of the Diagnostic tests may result in losing some or all of the non-volatile RAM data (such as stored settings, calibration constants, etc.). This could affect normal instrument operation in unpredictable ways. If this occurs, refer to Restoring Calibration Data later in this section.

After the amplifier is powered-up and the MPU has reset, the amplifier begins a sequence of test routines to determine if its kernel systems are operating properly. If any of these tests fails, then it is unlikely that the amplifier can communicate failure information to the mainframe. The flashing of a fault code on the front panel CH 1 and CH 2 LEDs indicates a particular failure. This fault code indicates which Kernel Test is failing.

The following description explains how to read the fault code:

- If the amplifier Kernel Tests detect a fault, then the CH 2 LED is flashed eight times to display a fault code. Each time the CH 2 LED turns on, count the occurrences. If the CH 1 LED is lit during a cycle of the CH 2 LED, then the test corresponding to the current count accumulated is the one which failed. Refer to the timing diagram in Figure 3-8 for an example LED fault code. The timing diagram illustrates a test number 2 failure.

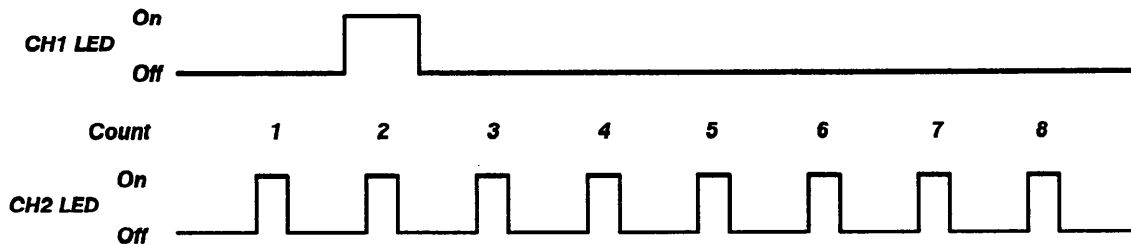

Figure 3-8 – Sample LED Fault Code Timing Diagram

The Kernel Tests are:

1. ROM Checksum Test
2. Non-volatile RAM Test
3. Housekeeper IC Test

- **Test 1:** The ROM Checksum Test computes a checksum of the content of the firmware ROM. This calculated checksum is then compared with a checksum stored in the ROM. If the checksums do not match, the test fails, and fault code 1 is reported. After the fault code is reported by flashing the front-panel LEDs, the amplifier attempts to begin normal operation, but it is unlikely that the instrument can function properly with a bad ROM Checksum.
- **Test 2:** The non-volatile RAM (NV RAM) Test verifies that the NV RAM is functioning properly. Since the NV RAM contains calibration information which must remain undamaged, this test does not alter critical data. If the testing algorithm detects a failure, then the amplifier reports a fault code of 2, and repeatedly loops the NV RAM Test. The instrument continues looping the NV RAM Test until the power is removed. Until the condition causing the NV RAM Test to fail is corrected, the mainframe does not recognize the amplifier.

The NV RAM Test could corrupt calibration data stored in the NV RAM if the power is cycled or removed during this test. If corruption occurs, then the Calconstant Checksum is corrupted as well. Furthermore, at the next power-up, the amplifier resets the calibration constants to default ROM settings and reports an amplifier calconstant checksum error during mainframe-invoked, Power-up Diagnostics. After the mainframe/amplifier system is run through an Enhanced Accuracy cycle, the amplifier is once again properly calibrated.

- **Test 3:** The Housekeeper IC Test verifies the functionality of the Housekeeper IC. The Housekeeper IC performs many 'housekeeping' chores of the amplifier; including channel sequencing, refreshing the analog control voltage system, latching amplifier step gain settings, and the communications with the mainframe. This test exercises this IC and records the ICs reactions using an algorithm similar to the algorithm that signature analysis uses. If the resulting signature of the Housekeeper IC does not match a known good signature, then the test fails and reports a fault code of 3. Also, the test is executed repeatedly if it fails. The instrument continues looping the Housekeeper IC Test until power is removed. Until the condition causing the Housekeeper IC Test to fail is corrected, the mainframe does not recognize the amplifier.

After all power-on Kernel Tests have completed and successfully passed, the amplifier initializes its settings and communicates with the mainframe.

Self Test/Extended Diagnostics – First, the amplifier must successfully power-up, initialize its settings, and establish communication with the mainframe. Then, the mainframe requests that the amplifier execute its Self-Test routines (unless the mainframe's Self-Tests are disabled, in which case all the Self-Tests are ignored). Return to normal operation or entry into the New Configuration calibration, as discussed below, indicates successful completion of Self-Test Diagnostics. Any failures cause the instrument to display the Extended Diagnostics menu. Record the displayed error codes for the failed circuit block(s). You may have to step through several pages of the menu display to find all the failure codes.

The format of the error index codes is based on the Extended Diagnostics menu structure. The Extended Diagnostics menus are in a three level hierarchy with the Block menu at the highest level. Each amplifier is one Block. A Block is broken into a number of parts or circuit areas in the Area menu, the second level. Touching the Area label at the bottom of the menu displays the Area menu for the selected Block. Each circuit Area has a Routine menu, the third level, associated with it that has one or more selectable Routines. Routines are the smallest test units that are selectable and runnable. This Block, Area, and Routine menu hierarchy generates the error index codes.

Extended Diagnostics error index codes are five digit codes whose first character indicates the subsystem or amplifier tested. The last four digits are hexadecimal (hex) numbers that indicate the Block, Area, Routine and specific failure mode. For example, R1241 is decoded as follows:

R	Right plug-in
1	Block name - plug-in
2	Area name - Group I
4	Routine name - Checksum Probe
1	Failure Identity - specific failure mode

The subsystem character of an error index code is one of the following, and indicates the compartment in which the amplifier is installed. In the tables in this section, only the four digit failure code is listed; the prefix L, C, or R is omitted.

L	Left
C	Center
R	Right

Front-panel controls are active during the Self-Test sequence and any disturbance causes a test failure.

Self-Test Diagnostics test the following:

- Attenuator relay driver
- Probe coding
- Calibration constant checksums
- Calibration constant values
- A/D and D/A converters
- Probe power fuses
- Signal path

Using the Self Tests/Extended Diagnostics – After all Extended Diagnostic/Self-Tests have run, any resultant error index codes appear on the display next to the associated circuit block names in the Extended Diagnostics menu. Each circuit block that had a failure gives the first error encountered and the number of failures in the Block. Select the label of a failed Block then select the Area label to get a more complete list of the error index codes in a Block. Selecting the Routine label shows the lowest level test routines in the selected Area. The currently selected Block, Area, and Routine are shown. Several operating mode selectors are available on the screen. When certain test routines are selected, some of these operating modes are unselectable.

Refer to the mainframe User's Reference manual for information on Extended Diagnostics or Extended Test menus and operation.

New Configuration Calibration

When an amplifier is first installed in a mainframe or when one is moved to a different compartment in the mainframe, the instrument is in a new configuration mode. After the instrument runs the Power-Up Diagnostics, it recalibrates itself for the new configuration. During this calibration, the message "**Powerup new configuration partial calibration occurring**" appears. If the calibration is successful (as indicated by a message), the instrument enters the normal operating mode.

Restoring Calibration Data

If the instrument power is turned off during probe calibration, self-calibration, Extended Diagnostics or other intense system activity, then some internal data may be corrupted. The display of the Extended Diagnostic menu when the power is turned on, indicates that this corruption has occurred.

If the Extended Diagnostics menu displays a Cksm Probe error (this error indicates that the power was turned off during probe calibration), then using the following procedure usually restores normal operation:

1. Note from the Extended Diagnostics menu which amplifier is at fault.
2. Exit the Extended Diagnostics menu.
3. Remove and re-install the probes on the amplifier that is at fault.
4. Repeat the calibration of these probes.
5. Run the Self-Tests and confirm that the tests pass.

If the Extended Diagnostics menu displays a Cksm Plug or any other new error, then using the following procedure usually restores normal operation:

1. Exit the Extended Diagnostic menu.
2. Wait for the self-calibration to complete and pass.
3. Run the Self-Tests and confirm that the tests pass.

Usually these procedure restore normal operation. If these procedures do not restore normal operation, then your mainframe or amplifier requires servicing.

Amplifier Memory Backup Power

The non-volatile RAM (A1U801 NV RAM) within the amplifier allows retention of the data in memory when the mainframe power is removed.

NV RAM stores system-configuration data such as the amplifier, mainframe, and probe IDs as well as the calibration constants. The data that the NV RAM stores, enable the amplifier to resume Enhanced Accuracy performance from a powered-down condition, without performing a full calibration (Enhanced Accuracy) operation.

The rated lifetime of the NV RAM's integral power source is ten years. If, on system power-up, the amplifier habitually loses Enhanced Accuracy status without a system configuration change (that is, the amplifier remains plugged into the same slot in the same mainframe), then the NV RAM might require replacement.

Field Replaceable Unit (FRU) Guide

This section correlates error index codes resulting from Diagnostic tests with the hybrid, integrated circuit (IC), module, or board FRU(s) suspected of causing each error. The FRU(s) in each category are listed in most-to-least probable cause order (assuming only one error is indicated). If any diagnostic errors occur, inspect the suspect FRU for loose connections and components. Repeat the Diagnostic test. If any diagnostic errors occur again, replace the suspect FRU(s) with a known good FRU(s). Verify that the new FRU is a correct replacement for the old FRU. If the old FRU contains firmware, then verify that the new firmware version is either the same version as, or an upgraded version of, the old firmware version.

Abbreviations of FRU Names—All boards are listed here with the abbreviation used in the FRU tables below:

Table 3-2 – Board FRU

<i>Abbreviation</i>	<i>Name</i>	<i>Designator</i>
Main	Main board	A1
Front2	Front Panel board	A2
Front3	Front Panel board	A3

Abbreviations of Component and Module Names—All active components and modules are listed here with the abbreviation used in the FRU tables below.

Table 3-3 – Component/Module FRUs

<i>Abbreviation</i>	<i>Name</i>	<i>Designator</i>
MPU	Processor	A1U700
EPROM	Firmware	on A1U700
RAM	Memory	A1U801
HK	Housekeeper	A1U600
Att1	Attenuator, channel 1	
Att2	Attenuator, channel 2	
Att3	Attenuator, channel 3	
Att4	Attenuator, channel 4	
Amp1	Amplifier, channel 1	A1U310
Amp2	Amplifier, channel 2	A1U410
Amp3	Amplifier, channel 3	A1U330
Amp4	Amplifier, channel 4	A1U430
FUSE	Probe power fuses	A1F1041, A1F1042, A1F1043, A1F1044

Error Index Codes—This table lists the error codes possible in the Kernel Tests.

Table 3-4 – Amplifier Kernel Error Index Codes

<i>Error Code</i>	<i>Suspect Module, Hybrid, or IC FRU(s)</i>	<i>Suspect Board FRU(s)</i>
1	EPROM, MPU	Main
2	NV RAM	Main
3	SUI, MPU	Main

This table lists the error messages possible in the Self-Tests and Extended Diagnostics.

Table 3-5 – Self-Tests/Extended Diagnostics Error Index Codes

<i>Routine</i>	<i>Area</i>	<i>Error Index</i>	<i>Suspect Module, Hybrid, or IC FRU(s)</i>	<i>Suspect Board FRU(s)</i>
Relay Drvr	Group I	-1111		Main
Probecodes	Group I	-1121		Main
Cksm Plug	Group I	-1131 ²	RAM ¹	Main
Cksm Probe	Group I	-1141 ²	RAM ¹	Main
Serial Sum	Group I	-1151		Main
ADC Test	Group II	-1211		Main
Fuse Test	Group II	-1221	FUSE	Main
ACVS Test	Group III	-1311	HK	Main
Gain Off 1	Signal Pth	-1811	Amp	Main
Gain Off 2	Signal Pth	-1821	Att, Amp	Main
Gain Off 3	Signal Pth	-1831	Amp, HK	Main
Gain Off 4	Signal Pth	-1841	Amp, HK	Main
Gain On 1	Signal Pth	-1851	Att, Amp, HK	Main
Gain On 2	Signal Pth	-1861	Att, Amp, HK	Main
Gain On 3	Signal Pth	-1871	Att, Amp, HK	Main
Gain On 4	Signal Pth	-1881	Att, Amp, HK	Main

¹When the RAM is replaced a new User Identification (UID) must be entered before this error can be cleared. See Programming the Unit Identification.

²These error indexes may also result from corruption of calibration data (refer to Restoring Calibration Data earlier in this section).

Interconnections are not listed but should be considered as possible problem sources.

Report errors by Routine and Error names to your Service Center.

This table lists the error messages resulting from Enhanced Accuracy. Enhanced Accuracy is available after the system has a 20-minute warmup period.

Table 3-6 – Self-Tests/Extended Diagnostics Error Index Codes

<i>Routine</i>	<i>Area</i>	<i>Error Index IC FRU(s)</i>	<i>Suspect Hybrid/ FRU(s)</i>	<i>Suspect Board FRU(s)</i>
Probe Gain	Ch 1 Cal	-1411	Att1	
Atten Gain	Ch 1 Cal	-1421	Att1	
Step Gain	Ch 1 Cal	-1431	Amp1	Main
BWL Match	Ch 1 Cal	-1441	Amp1	Main
Gain	Ch 1 Cal	-1451	Att1, Amp1	Main
Output Err	Ch 1 Cal	-1461	Amp1	Main
Balance	Ch 1 Cal	-1471	Att1, Amp1	Main
Coarse Dac	Ch 1 Cal	-1481	Amp1	Main
Fine Dac	Ch 1 Cal	-1491	Amp1	Main
Spare Gain	Ch 1 Cal	-14A1	Amp1	Main
Probe Gain	Ch 2 Cal	-1511	Att2	
Atten Gain	Ch 2 Cal	-1521	Att2	
Step Gain	Ch 2 Cal	-1531	Amp2	Main
BWL Match	Ch 2 Cal	-1541	Amp2	Main
Gain	Ch 2 Cal	-1551	Att2, Amp2	Main
Output Err	Ch 2 Cal	-1561	Amp2	Main
Balance	Ch 2 Cal	-1571	Att2, Amp2	Main
Coarse Dac	Ch 2 Cal	-1581	Amp2	Main
Fine Dac	Ch 2 Cal	-1591	Amp2	Main
Spare Gain	Ch 2 Cal	-15A1	Amp2	Main
Probe Gain	Ch 3 Cal	-1611	Att3	
Atten Gain	Ch 3 Cal	-1621	Att3	
Step Gain	Ch 3 Cal	-1631	Amp3	Main
BWL Match	Ch 3 Cal	-1641	Amp3	Main
Gain	Ch 3 Cal	-1651	Att3, Amp3	Main
Output Err	Ch 3 Cal	-1661	Amp3	Main
Balance	Ch 3 Cal	-1671	Att3, Amp3	Main
Coarse Dac	Ch 3 Cal	-1681	Amp3	Main
Fine Dac	Ch 3 Cal	-1691	Amp3	Main
Spare Gain	Ch 3 Cal	-16A1	Amp3	Main

Table 3-6 – Self-Tests/Extended Diagnostics Error Index Codes (cont)

<i>Routine</i>	<i>Area</i>	<i>Error Index IC FRU(s)</i>	<i>Suspect Hybrid/ FRU(s)</i>	<i>Suspect Board FRU(s)</i>
Probe Gain	Ch 4 Cal	-1711	Att4	
Atten Gain	Ch 4 Cal	-1721	Att4	
Step Gain	Ch 4 Cal	-1731	Amp4	Main
BWL Match	Ch 4 Cal	-1741	Amp4	Main
Gain	Ch 4 Cal	-1751	Att4, Amp4	Main
Output Err	Ch 4 Cal	-1761	Amp4	Main
Balance	Ch 4 Cal	-1771	Att4, Amp4	Main
Coarse Dac	Ch 4 Cal	-1781	Amp4	Main
Fine Dac	Ch 4 Cal	-1791	Amp4	Main
Spare Gain	Ch 4 Cal	-17A1	Amp4	Main

Report errors by Routine and Area names to your Service Center.

Fuse Troubleshooting

Failure code 1221 indicates that one or more probe power fuses are defective.

Refer to Figure 3-1 (FRU locator) for fuse locations.

To find a defective fuse, remove the amplifier from the mainframe, and use a Multimeter to check for continuity across each fuse. Replace all defective fuses. Then, install the amplifier in the mainframe and verify that the diagnostic error does not reappear.

The most likely cause of a blown fuse is a short circuit applied at the front-panel TEKPROBE® input connector. If a newly installed fuse blows with nothing connected at the TEKPROBE® input connector, then look for a short circuit on the A1 Main board or on the flexible circuit connecting the A1 Main board to the TEKPROBE® input connector.

Jumpers

For normal operation, six jumper are installed. Refer to Figure 3-9, and verify that the jumpers are installed as follows:

- J611 in the vertical position
- J740 in the vertical position
- TP901 connected to TP902
- TP903 connected to TP904
- TP905 connected to TP906
- TP907 connected to TP908

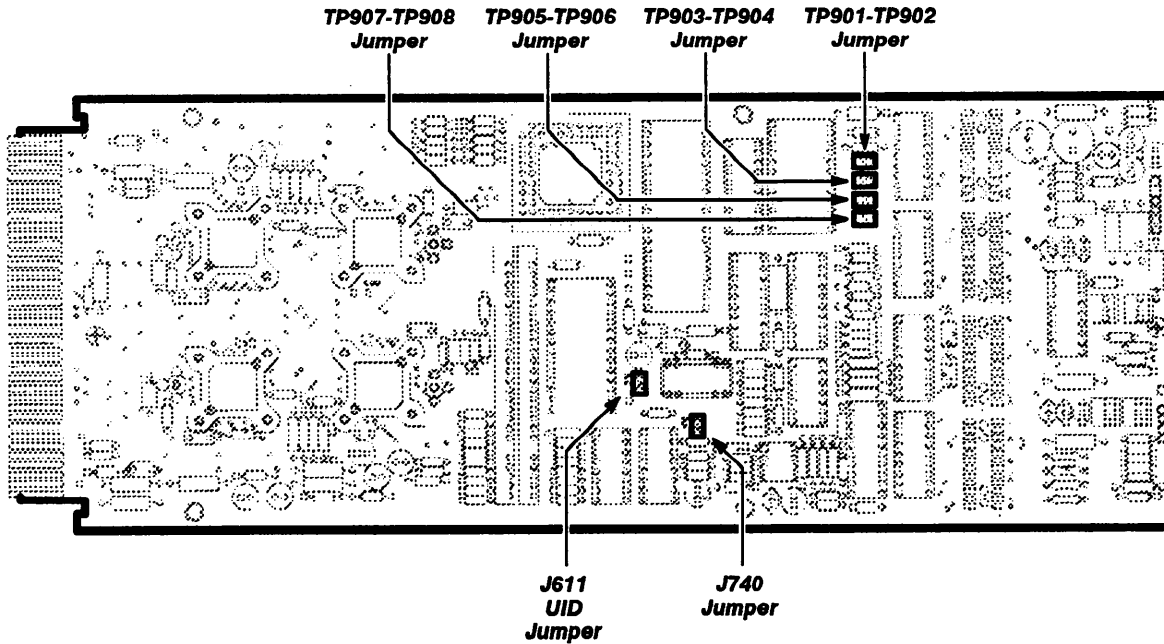

Figure 3-9 — Jumper Locator

Theory of Operation

The Tektronix 11A34 Four Channel Amplifier is a wide bandwidth four-channel amplifier that plugs into any 11000-Series Oscilloscope that accommodates amplifiers.

Block Diagram Description

This section describes and illustrates (refer to Fig. 4-1) the amplifier block diagram; including signal flow and control flow. This section also discusses the power supplies for the amplifier.

Signal Flow

The CH 1, CH 2, CH 3 and CH 4 Amplifier circuits are identical, therefore this section describes only the CH 1 Amplifier.

The display of a signal begins with the inputting of a signal directly to the CH 1 input connector (perhaps with a probe) and proceeds as follows:

CH 1 input connector → CH 1 Attenuator →
→ CH 1 Aux Signal
CH 1 Amplifier → CH 1 Trigger Signal
→ CH 1 Display Signal

The input coupling mode is either AC, DC, or Off. In the AC and DC coupling modes, the input signal is coupled to the Attenuator. In the Off Coupling mode, the signal path is open.

During self-calibration, the mainframe supplies the signal to the CH 1 Attenuator.

The CH 1 Attenuator contains resistive dividers, capacitive dividers, an ac coupling capacitor, relays, and a buffer amplifier. The CH 1 Amplifier provides gain switching and bandwidth limit filters.

The amplifier contains a microprocessor (MPU) that communicates with the mainframe. The MPU also constantly monitors the input Overload Sense and the Probe Data communication lines. The operation of the MPU is through the internally stored program in its read only memory (ROM). The MPU stores the amplifier calibration constants in random access memory (RAM). A battery backs-up memory; therefore the internal calibration constants are not lost upon power-down. Also, when powering-down, the mainframe stores the oscilloscope's settings. When the system re-powers, the mainframe restores and transmits these settings to the amplifier.

The MPU communicates with the mainframe through a peripheral IC called the Housekeeper. The Housekeeper converts the 8-bit data bytes from the MPU into a serial data signal. This signal is sent to the mainframe. Conversely, the Housekeeper converts the serial data signal from the mainframe into 8-bit data bytes for the processor to read. The MPU stores the channel switching sequence in the Housekeeper. The Housekeeper also updates the analog control voltages.

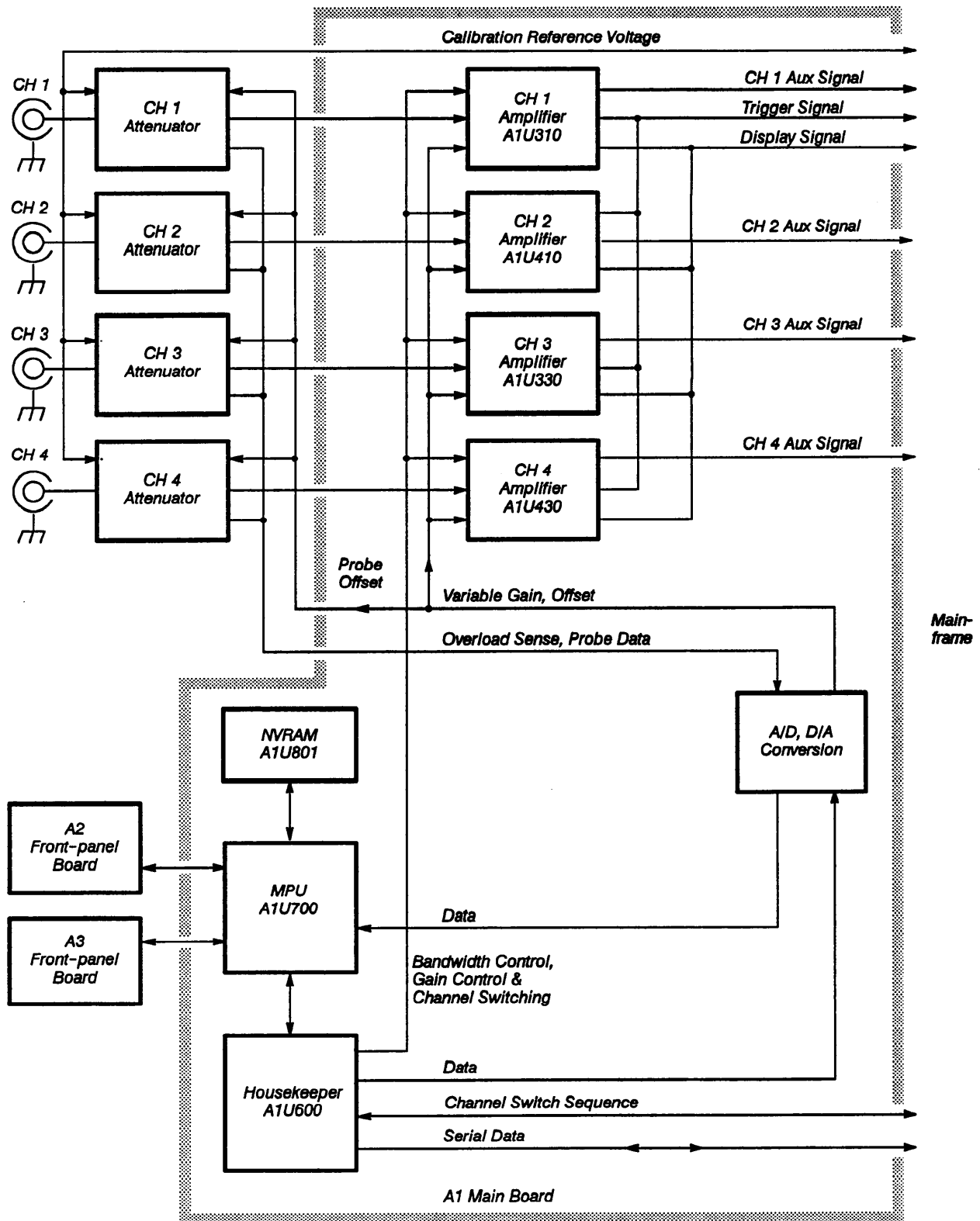

Figure 4-1 – 11A34 Four-Channel Amplifier Block Diagram

The MPU uses an analog-to-digital (A/D) converter to read the value of the Overload Sense and Probe Data lines. The A/D converter is also used in the Self-Tests.

The MPU reads the front-panel pushbuttons. The MPU tells the mainframe when a front-panel button is pushed. The mainframe then tells the amplifier what action to take (for example, display the selected channel and turn on that channel's respective front-panel LED).

Control Flow

Under the control of the mainframe's channel switch sequencing signals, the Housekeeper sequentially turns a channel on or off. The MPU and Housekeeper control the settings of the amplifier and the attenuator.

Power

The mainframe supplies all the power to the amplifier.

Replaceable Parts

This section contains a list of the components that are replaceable for the 11A34 Four-Channel Amplifier. As described below, use this list to identify and order replacement parts.

Parts Ordering Information

Replacement parts are available from or through your local Tektronix, Inc. service center or representative.

Changes to Tektronix instruments are sometimes made to accommodate improved components as they become available and to give you the benefit of the latest circuit improvements. Therefore, when ordering parts, it is important to include the following information in your order:

- Part number
- Instrument type or model number
- Instrument serial number
- Instrument modification number, if applicable

If a part you order has been replaced with a different or improved part, your local Tektronix service center or representative will contact you concerning any change in the part number.

Change information, if any, is located at the rear of this manual.

Module Replacement

The 11A34 Four-Channel Amplifier is serviced by module replacement so there are three options you should consider:

- **Module Exchange.** In some cases you may exchange your module for a remanufactured module. These modules cost significantly less than new modules and meet the same factory specifications. For more information about the module exchange program, call 1-800-TEKWIDE, ext. BV 5799.
- **Module Repair.** You may ship your module to us for repair, after which we will return it to you.
- **New Modules.** You may purchase new replacement modules in the same way as other replacement parts.

Using the Replaceable Parts List

The tabular information in the Replaceable Parts List is arranged for quick retrieval. Understanding the structure and features of the list will help you find the all the information you need for ordering replacement parts.

Item Names

In the Replaceable Parts List, an Item Name is separated from the description by a colon (:). Because of space limitations, an Item Name may sometimes appear as incomplete. For further Item Name Identification, U.S. Federal Cataloging Handbook H6-1 can be used where possible.

Indentation System

This parts list is indented to show the relationship between items. The following example is of the indentation system used in the Description column:

1	2	3	4	5	Name & Description
					<i>Assembly and/or Component</i>
					<i>Attaching parts for Assembly and/or Component</i> <i>(END ATTACHING PARTS)</i>
					<i>Detail Part of Assembly and/or Component</i>
					<i>Attaching parts for Detail Part</i> <i>(END ATTACHING PARTS)</i>
					<i>Parts of Detail Part</i>
					<i>Attaching parts for Parts of Detail Part</i> <i>(END ATTACHING PARTS)</i>

Attaching parts always appear at the same indentation as the item it mounts, while the detail parts are indented to the right. Indented items are part of, and included with, the next higher indentation. Attaching parts must be purchased separately, unless otherwise specified.

Abbreviations

Abbreviations conform to American National Standards Institute (ANSI) standard Y1.1

CROSS INDEX - MFR. CODE NUMBER TO MANUFACTURER

Mfr. Code	Manufacturer	Address	City, State, Zip Code
01536	TEXTRON INC CAMCAR DIV SEMS PRODUCTS UNIT	1818 CHRISTINA ST	ROCKFORD IL 61108
22599	AMERACE CORP ESNA DIV	15201 BURBANK BLVD SUITE C	VAN NUYS CA 91411-3532
80009	TEKTRONIX INC	14150 SW KARL BRAUN DR PO BOX 500	BEAVERTON OR 97077-0001
83385	MICRODOT MFG INC GREER-CENTRAL DIV	3221 W BIG BEAVER RD	TROY MI 48098
91260	CONNOR SPRING AND MFG CO A SLOSS AND BRITTAN INC CO	1729 JUNCTION AVE	SAN JOSE CA 95112
92101	SCHULZE MFG	50 INGOLD RD	BURLINGAME CA 94010-2206
TK1326	NORTHWEST FOURSLIDE INC	18224 SW 100TH CT	TUALATIN OR 97062
TK1918	SHIN-ETSU POLYMER AMERICA INC	1181 NORTH 4TH ST	SAN JOSE CA 95112

Fig. & Index No.	Tektronix Part No.	Serial/Assembly No.		Qty	12345 Name & Description	Mfr.	
		Effective	Dscnt			Code	Mfr. Part No.
1-1	366-0600-00			4	PUSH BUTTON:0.269 X 0.409,ABS	80009	366-0600-00
-2	366-1058-00			1	KNOB:GRAY,0.625 X 0.255 X 0.485 (ATTACHING PARTS)	80009	366-1058-00
-3	214-1095-00			1	PIN,SPRING:0.187 L X 0.094 OD,STL,CD PL (END ATTACHING PARTS)	22599	52-022-094-0187
-4	105-0076-04			1	RELEASE BAR,LCH:PLUG-IN UNIT	80009	105-0076-04
-5	214-1280-00			1	SPRING,HLCPS:0.14 OD X 1.126 L,TWIST LOOP	91260	ORDER BY DESCR
-6	214-1054-00			1	SPRING,FLAT:0.825 X 0.322,SST	TK1326	ORDER BY DESCR
-7	105-0075-00			1	BOLT,LATCH:	80009	105-0075-00
-8	333-3164-00			1	PANEL,FRONT: (ATTACHING PARTS)	80009	333-3164-00
-9	211-0392-00			4	SCREW,MACHINE:4-40 X 0.25,FLH,82 DEG,STL (END ATTACHING PARTS)	80009	211-0392-00
-10	348-0235-00			2	SHLD GSKT,ELEK:FINGER TYPE,4.734 L	92101	ORDER BY DESCR
-11	386-5219-00			1	SUBPANEL,FRONT:	80009	386-5219-00
-12	670-9336-00			2	CIRCUIT BD ASSY:FRONT PANEL (SEE A2,A3) (ATTACHING PARTS)	80009	670-9336-00
-13	211-0390-00			4	SCREW,MACHINE:2-56 X 0.188,FLH,STL CD PL (END ATTACHING PARTS)	80009	211-0390-00
-14	174-0159-00			2	CA ASSY,SP,ELEC:6.26 AWG,3.0 L,RIBBON	80009	174-0159-00
-15	426-2061-00			1	FR SECT,PLUG-IN:LOWER,ALUMINUM (ATTACHING PARTS)	80009	426-2061-00
-16	211-0392-00			2	SCREW,MACHINE:4-40 X 0.25,FLH,82 DEG,STL (END ATTACHING PARTS)	80009	211-0392-00
-17	334-3540-00			1	MARKER,IDENT:MARKED WARNING	80009	334-3540-00
-18	119-2000-00	B010100	B021141	4	ATTENUATOR:ACTIVELY TRIMMED NOVAR ATTENUATOR & BUFFER AMPLIFIER	80009	119-2000-00
	119-2000-02	B021142		4	ATTENUATOR:ACTIVELY TRIMMED NOVAR ATTENUATOR & BUFFER AMPLIFIER ASSY (ATTACHING PARTS)	80009	119-2000-02
-19	211-0390-00			16	SCREW,MACHINE:2-56 X 0.188,FLH,STL CD PL	80009	211-0390-00
-20	211-0391-00			8	SCREW,MACHINE:2-56 X 0.437,P4,STL CD PL (END ATTACHING PARTS)	80009	211-0391-00
-21	354-0654-00			4	RING,CONN ALIGN:BNC	80009	354-0654-00
-22	352-0780-00			4	HOLDER,CNDC:ELASTOMERIC	80009	352-0780-00
-23	131-3383-01			8	CONN ASSY,ELEC:ELASTOMERIC,3.8MM X 3.0MM X 24.0MM,0.4MM L CONTACT PT	TK1918	.4PX24X3.8X3.0
-24	220-0022-00			4	NUT BLK:0.4 X 0.25 X 0.33,4-40 THRU,NI SIL (ATTACHING PARTS)	80009	220-0022-00
-25	211-0304-00			4	SCR,ASSEM WSHR:4-40 X 0.312,PNH,STL,T9 TORX (END ATTACHING PARTS)	01536	ORDER BY DESCR
-26	426-2060-00			1	FR SECT,PLUG-IN:UPPER,ALUMINUM (ATTACHING PARTS)	80009	426-2060-00
-27	211-0392-00			2	SCREW,MACHINE:4-40 X 0.25,FLH,82 DEG,STL (END ATTACHING PARTS)	80009	211-0392-00
-28	334-3438-00			1	MARKER,IDENT:MARKED TURN OFF POWER	80009	334-3438-00
-29	214-1061-00			1	CONTACT,ELEC:GROUNDING,CU BE	80009	214-1061-00
-30	337-1064-12			2	SHIELD,ELEC:SIDE FOR PLUG-IN UNIT	80009	337-1064-12
-31	670-8976-00			1	CIRCUIT BD ASSY:MAIN (SEE A1)	80009	670-8976-00
-32	156-2962-00	B010100	B032283	1	.MICROCKT,DGTL:NMOS,MICROCOMPUTER,8 BIT W/ .SOCKET,EPROM	80009	156-2962-00
-33	160-4009-04	B010100	B020831	1	.MICROCKT,DGTL:HMOS,16385 X 8 EPROM,PRGM	80009	160-4009-04
	160-4009-05	B020832	B030889	1	.MICROCKT,DGTL:HMOS,16385 X 8 EPROM,PRGM	80009	160-4009-05
	160-4009-06	B030890	B031650	1	.MICROCKT,DGTL:HMOS,16385 X 8 EPROM,PRGM	80009	160-4009-06
	160-4009-07	B031651	B031895	1	.MICROCKT,DGTL:HMOS,16385 X 8 EPROM,PRGM	80009	160-4009-07
	160-4009-08	B031896	B032283	1	.MICROCKT,DGTL:HMOS,16385 X 8 EPROM,PRGM	80009	160-4009-08
	160-3663-00	B032284		1	.MICROCKT,DGTL:CMOS,8 BIT MICROCOMPUTER,PRGM	80009	160-3663-00
-34	165-2089-04	B010100	B031044	4	.MICROCKT,LINEAR:VERT PREAMP,200 OHM	80009	165-2089-04
	165-2089-06	B031045		4	.MICROCKT,LINEAR:VERTICAL PREAMP,200 OHM	80009	165-2089-06
-35	156-2625-00			1	.MICROCKT,DGTL:NMOS,CUSTOM,SENECHAL	80009	156-2625-00
-36	343-0543-00			2	RETAINER,MIRROR:LEFT & RIGHT,ABS BLACK	80009	343-0543-00
-37	407-3363-00			1	BRACKET,HEAT SK:ALUMINUM (ATTACHING PARTS)	80009	407-3363-00
-38	211-0711-00			4	SCR,ASSEM WSHR:6-32 X 0.25,PNH,STL,TORX,T15 (END ATTACHING PARTS)	01536	ORDER BY DESCR
-39	386-5296-00			1	PANEL,REAR:	80009	386-5296-00

Fig. & Index No.	Tektronix Part No.	Serial/Assembly No. Effective Dscont	Qty	12345	Name & Description	Mfr. Code	Mfr. Part No.
1- -40	213-0904-00		4		(ATTACHING PARTS) SCREW,TPG,TR:6-32 X 0.5,PNH,STL (END ATTACHING PARTS)	83385	ORDER BY DESCR
					STANDARD ACCESSORIES		
	070-5921-01		1		MANUAL,TECH:USERS,11A34	80009	070-5921-01
	070-6697-01		1		PROCEDURE:INCOMING INSPECTION,11A34	80009	070-6697-01
					OPTIONAL ACCESSORIES		
	070-6785-02		1		MANUAL,TECH:SERVICE REF,11A34	80009	070-6785-02

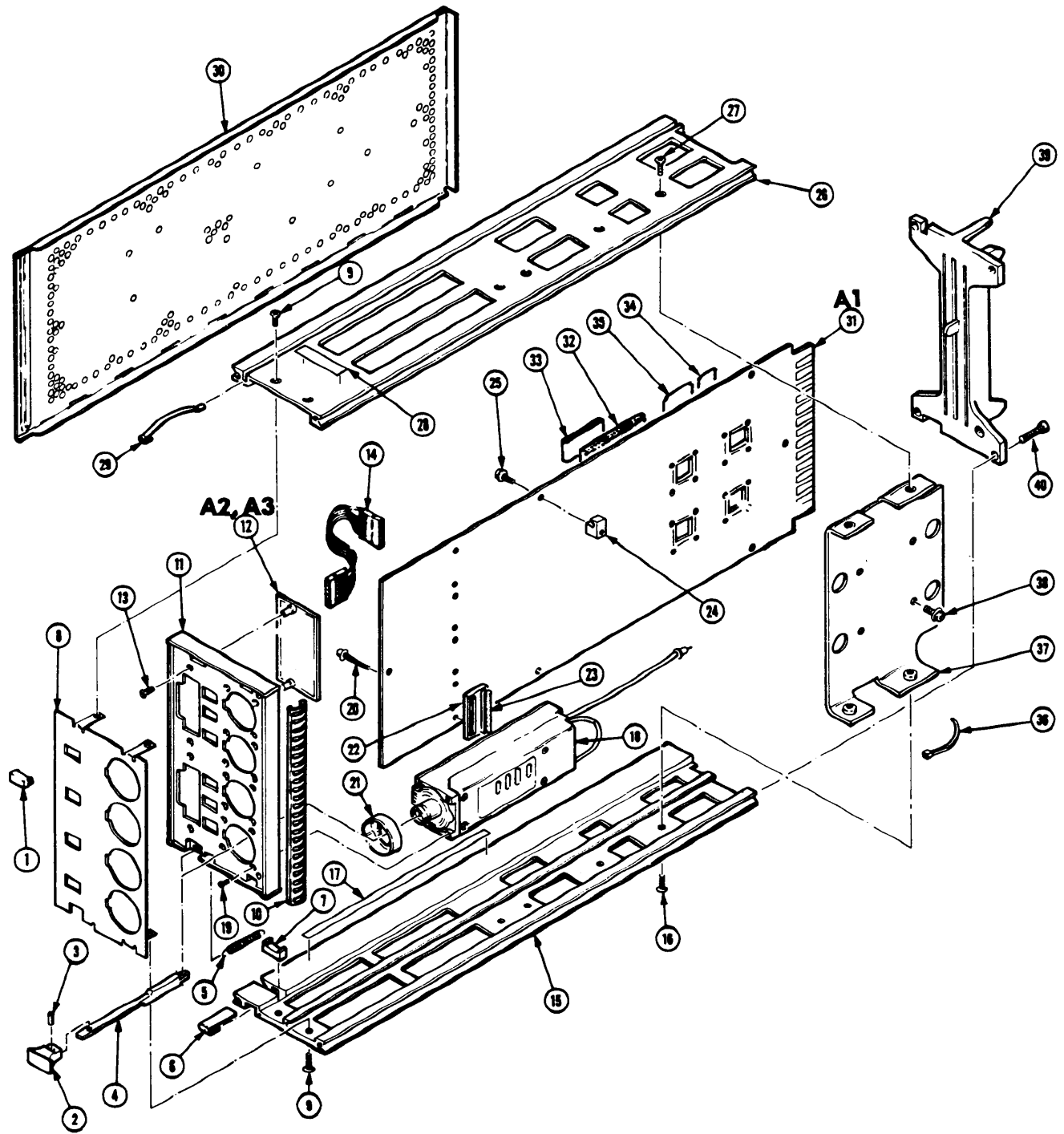

FIG. 1 EXPLODED
11A34

MANUAL CHANGE INFORMATION

At Tektronix, we continually strive to keep up with latest electronic developments by adding circuit and component improvements to our instruments as soon as they are developed and tested.

Sometimes, due to printing and shipping requirements, we can't get these changes immediately into printed manuals. Hence, your manual may contain new change information on following pages.

A single change may affect several sections. Since the change information sheets are carried in the manual until all changes are permanently entered, some duplication may occur. If no such change pages appear following this page, your manual is correct as printed.

SEND TO: TEKTRONIX, INC.
 LAB INSTRUMENTS MARKETING SUPPORT
 P.O. BOX 500, DEL STA 39-327
 BEAVERTON, OREGON 97077

**11000-SERIES OSCILLOSCOPE
 PROBLEM REPORT**

A INSTRUMENT CONFIGURATION:

Instrument	Section	ROM (Version)	ID # (Serial Number)

Option Information

COMPANY NAME: _____
 USER: _____
 B ADDRESS: _____
 CITY: _____ STATE: _____ ZIP: _____
 PHONE: _____ EXTENSION: _____
 SUBMITTED BY: _____ DATE: _____

REASON FOR REPORT
 Hardware/Mechanical Problem
 Software/Firmware Problem
 Documentation Problem
 Suggested Enhancement C

IS THE PROBLEM REPRODUCIBLE?
 Yes No Intermittent

SYSTEM DESCRIPTION: (Hardware, software, firmware and host related to the problem)

D

DESCRIPTION OF PROBLEM:

E

LIST ENCLOSURES:



Instructions For Completing The Problem Report

- I. Please type or print clearly. Use a separate Problem Report (PR) for each problem.
- II. **SECTION A**
Fill in the instrument configuration table, including all plug-in units, modules, and probes installed in the oscilloscope. The information can be found in one of the menus under the **UTILITY** major menu.
Instrument: Write the instrument name (e.g., 11301, 11401, 11A32, etc.).
Section (Microprocessor Subsystem): If the instrument has more than one section write the section name. For plug-ins, write in which mainframe slot they are located (e.g., left, center, right).
ROM (Version): Write the rom version number for each instrument and section. Instruments with more than one section will have more than one version number.
ID# (Serial Number): Write the serial number for each instrument. At the factory the ID number is programmed to be the instrument's serial number. If this value has been changed, please write the serial number physically attached to the instrument (mainframes: front panel, plug-in units: top rail).
- III. **SECTION B**
Use the complete company mailing address. Include the name and phone number of the person reporting the error. Also, be sure to fill in the name of the person submitting the PR.
- IV. **SECTION C**
Check the reason for the report and whether the problem is reproducible. We cannot fix a problem when we cannot reproduce the problem condition.
- V. **SECTION D**
Give a complete description of the system configuration on which the problem occurred. Include related peripherals, interfaces, options, special switch and/or strap settings and operating system.
- VI. **SECTION E**
Describe the problem completely. Include any information which might help in evaluating the error with the PR. If you have determined a procedure to avoid the error condition, please include this procedure. If this problem prevents you from accomplishing any useful work with the product, please state this fact. Be sure to include with the PR any information (programs, listings, hard copies, etc.) which will help us duplicate your problem.
- VII. **SECTION F**
This section is for use by Tektronix Lab Instruments Marketing Support personnel. **DO NOT WRITE IN THIS SPACE.**
- VIII. Mail **all** copies of the Problem Report to:
TEKTRONIX, INC.
LAB INSTRUMENTS MARKETING SUPPORT
P.O. BOX 500, DEL STA 39-327
BEAVERTON, OREGON 97077

INTERNAL USE ONLY
(DO NOT WRITE BELOW THIS LINE)

F

DATE RECEIVED

IR #
